

Operating Instructions

BA 2010 EN 05.04

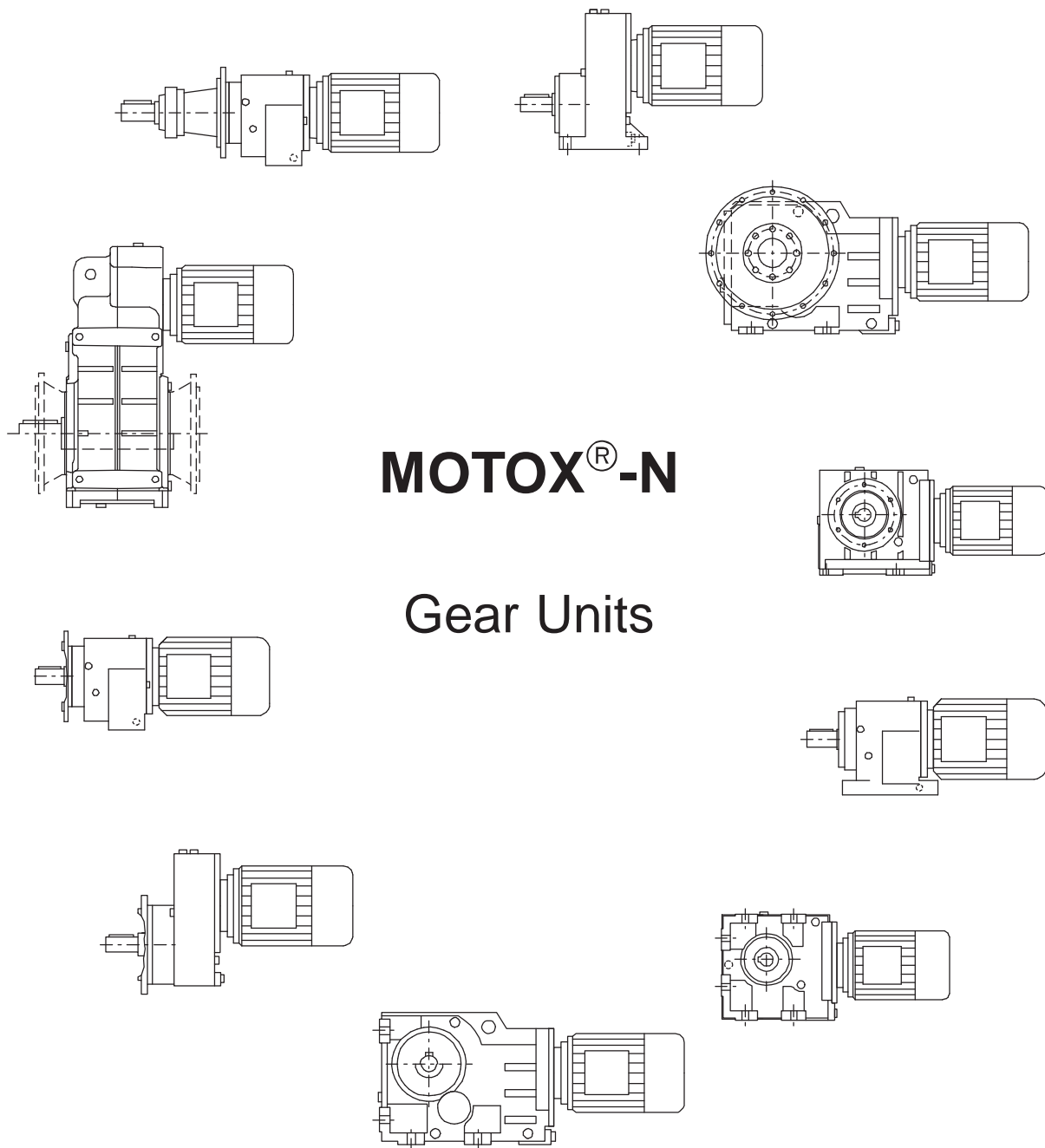

MOTOX[®]-N

Gear Units

FLENDER
TÜBINGEN

FLENDER TÜBINGEN GMBH · Bahnhofstr. 40-44 · D-72072 Tübingen
Telefon +49 (0) 70 71 - 707 0 · Fax +49 (0) 70 71 - 707 400 · <http://www.flender.com>
E-mail: sales-motox@flender-motox.com
A company of the Flender group

Contents

| | | |
|-----------|---|-----------|
| 1. | Important instructions | 6 |
| 1.1 | Instruction symbols in the operating instructions | 6 |
| 1.2 | General instructions | 6 |
| 1.3 | Amendments | 7 |
| 2. | Safety instructions | 8 |
| 2.1 | Intended use | 8 |
| 2.2 | General safety instructions | 8 |
| 3. | Technical data | 9 |
| 3.1 | Type designations | 9 |
| 3.2 | General technical data | 10 |
| 3.3 | Weights | 11 |
| 3.4 | Sound-pressure level | 11 |
| 3.5 | Mounting positions | 12 |
| 3.5.1 | One-stage helical gear units | 13 |
| 3.5.2 | Two and three-stage helical gear units | 14 |
| 3.5.3 | Bevel-helical gear units | 17 |
| 3.5.4 | Parallel shaft helical gear units | 19 |
| 3.5.5 | Helical worm gear units | 20 |
| 3.5.6 | Tandem gear unit - compound helical gear unit | 21 |
| 3.6 | Oil quantities | 22 |
| 3.6.1 | Helical gear units | 22 |
| 3.6.2 | Bevel-helical gear units | 23 |
| 3.6.3 | Parallel shaft helical gear units | 24 |
| 3.6.4 | Helical worm gear units | 24 |
| 3.6.5 | Tandem gear unit - compound helical gear unit | 25 |
| 3.6.5.1 | Two and three-stage helical gear units | 25 |
| 3.6.5.2 | Bevel-helical gear units | 26 |
| 3.6.5.3 | Parallel shaft helical gear units | 28 |
| 3.6.5.4 | Helical worm gear units | 29 |
| 4. | Technical description | 30 |
| 4.1 | General description | 30 |
| 4.2 | Housing | 30 |
| 4.3 | Toothed components | 30 |
| 4.4 | Lubrication | 30 |
| 4.5 | Shaft bearing | 30 |
| 4.6 | Shaft seals | 30 |
| 4.7 | Cooling | 30 |
| 4.8 | Couplings | 30 |
| 4.9 | Backstop | 31 |
| 4.10 | Rating plates | 31 |
| 4.11 | Paint coats | 32 |
| 4.11.1 | General | 32 |
| 4.11.2 | Painted version | 32 |
| 4.11.3 | Primed version | 33 |
| 5. | Incoming goods, Handling and Storage | 34 |
| 5.1 | Incoming goods | 34 |
| 5.2 | Handling | 34 |
| 5.3 | Storage | 35 |

| | | |
|-----------|---|-----------|
| 6. | Installation | 36 |
| 6.1 | General information on installation | 36 |
| 6.2 | Fastening in the case of reversing operation or high shock loads | 36 |
| 6.3 | Drives with foot mounting | 37 |
| 6.3.1 | Foundation | 37 |
| 6.3.2 | Installing gear units with foot mounting | 37 |
| 6.4 | Drive units in foot or flange version | 37 |
| 6.5 | Drive units with C-type housing flange | 38 |
| 6.6 | Installation of input drive and output drive elements on gear unit shafts | 40 |
| 6.7 | Steel safety cover for hollow shaft and shrink disc | 41 |
| 6.8 | Cast iron end cover for hollow shaft | 42 |
| 6.9 | Shaft-mounting gear unit with hollow shaft and parallel key, hollow shaft and splines, hollow shaft and shrink disk | 43 |
| 6.9.1 | Mounting the hollow shaft | 43 |
| 6.9.2 | Remove hollow shaft and parallel key | 45 |
| 6.9.3 | Suggested design for threaded piece and disc | 46 |
| 6.10 | Shrink disc | 47 |
| 6.10.1 | Mounting the shrink disc | 47 |
| 6.10.2 | Pulling off the shrink disc | 48 |
| 6.10.3 | Cleaning and greasing the shrink disc | 48 |
| 6.11 | Attachment of standard motors | 49 |
| 6.11.1 | Fit standard motor on coupling housing with torsionally flexible coupling | 49 |
| 6.11.2 | Using a clamp ring, attach standard motor to coupling housing | 50 |
| 6.12 | Motor base plate | 52 |
| 6.12.1 | Mounting IEC motors up to size 112 | 53 |
| 6.12.2 | Mounting IEC motors sizes 132 to 200 | 54 |
| 6.12.3 | Mounting IEC motors from size 225 | 55 |
| 6.13 | Torque arm with shaft-mounted gear units | 56 |
| 6.13.1 | Fit torque arm to bevel helical gear unit | 56 |
| 6.13.2 | Mounting torque arm on parallel shaft helical gear unit | 57 |
| 6.13.3 | Mounting torque arm on helical worm gear unit | 58 |
| 7. | Start-up | 59 |
| 7.1 | Oil level check before start-up | 59 |
| 7.2 | Fill in oil | 59 |
| 7.3 | Ventilation of the gear unit | 59 |
| 7.3.1 | Filter for ventilation or pressure relief valve without securing clip | 59 |
| 7.3.2 | Pressure relief valve with securing clip (special version) | 59 |
| 7.4 | Start-up after long-term preservation | 60 |
| 7.4.1 | Long-term preservation up to 18 months | 60 |
| 7.4.2 | Long-term preservation up to 36 months | 60 |
| 7.5 | Drive with backstop (special version) | 60 |
| 8. | Operation | 61 |
| 9. | Faults, causes and remedy | 62 |

| | | |
|------------|---|-----------|
| 10. | Maintenance and repair | 65 |
| 10.1 | General information for maintenance | 65 |
| 10.2 | Description of maintenance and repair work | 66 |
| 10.2.1 | Oil level | 66 |
| 10.2.1.1 | Check the oil level in the gear housing | 67 |
| 10.2.1.2 | Checking the oil level by the oil sight glass (special version) | 69 |
| 10.2.1.3 | Checking the oil level by the oil dipstick (special version) | 69 |
| 10.2.1.4 | Checking the oil level sensor (special version) | 69 |
| 10.2.2 | Oil quality | 69 |
| 10.2.3 | Oil change | 70 |
| 10.2.4 | Replacing bearings | 71 |
| 10.2.5 | Relubrication of the rolling bearings in drive units | 71 |
| 10.2.6 | Change rolling bearing grease | 72 |
| 10.2.7 | Seal check | 72 |
| 10.2.8 | Clean ventilation filter | 72 |
| 10.2.9 | Clean drive | 72 |
| 10.2.10 | Checking tightness of fastening bolts | 73 |
| 10.2.11 | Inspection of the drive | 73 |
| 10.2.12 | Carry out maintenance on slip coupling | 73 |
| 10.3 | Lubricants | 74 |
| 11. | Disposal | 78 |
| 12. | Stocking spare parts and customer service addresses | 79 |
| 12.1 | Stocking spare parts | 79 |
| 12.2 | Spare parts lists | 80 |
| 12.2.1 | One-stage helical gear units | 80 |
| 12.2.2 | Two and three-stage helical gear units | 81 |
| 12.2.3 | Bevel-helical gear units | 82 |
| 12.2.4 | Parallel shaft helical gear units | 83 |
| 12.2.5 | Helical worm gear units | 84 |
| 12.3 | Customer-service addresses | 85 |
| | FLENDER TÜBINGEN GMBH Germany | 85 |
| | FLENDER TÜBINGEN GMBH Europe | 86 |
| | FLENDER TÜBINGEN GMBH International | 87 |
| 13. | Declaration by the manufacturer, Declaration of Conformity | 89 |
| 13.1 | Declaration by the manufacturer | 89 |
| 13.2 | EC Declaration of Conformity | 90 |

1. Important instructions

1.1 Instruction symbols in the operating instructions

Instructions relating to operating safety are emphasized as follows:



Danger.
Possible consequences: Death or very severe injuries.



Caution.
Possible consequences: Damage to the drive and the environment.



Note.
Pointers for application and useful information.



Drives in ATEX version.
Instructions and measures applying in particular to drives in ATEX version.

1.2 General instructions

These operating instructions are an integral part of the gear unit delivery.

These operating instructions apply to the standard version of the **MOTOX[®]-N** gear unit:

Helical gear units E, Z and D Size 38 - 188.

Bevel-helical gear units K Size 38 - 188.

Parallel shaft helical gear units F Size 38B - 188B.

Helical worm gear units C Size 38 - 88.



Note.
Special types of drive and their additional equipment are governed by the special contractual agreements and technical documents.
Note also the other operating instructions for couplings, motors, brake motors, additional equipment for motors, etc., delivered with the equipment.



Note.
We accept no responsibility for damage or disruption resulting from disregard of these operating instructions.

Keep these operating instructions in the vicinity of the gear unit.

Read these operating instructions before working with the drive.

Only a precise knowledge of these operating instructions will guarantee reliable, faultfree operation of the drive by avoiding operating errors and improper use.

The drives described in these Instructions reflect the state of technical development at the time these instructions went to print.

In the interest of technical progress we reserve the right to make changes to the individual assemblies and accessories which we regard as necessary to preserve their essential characteristics and improve the efficiency and safety of the drive.

The copyright to these operating instructions is held by **FLENDER TÜBINGEN GMBH**.

These operating instructions must not be wholly or partly reproduced, used in any unauthorised way for competitive purposes or made available to third parties without our agreement.

Amendments or additions to these operating instructions may be made only by us; otherwise any guarantee claim against us will lapse.

Technical enquiries should be addressed to the following works

FLENDER TÜBINGEN GMBH

Postfach 1709 · D-72007 Tübingen

Bahnhofstr. 40-44 · D-72072 Tübingen

Telefon +49 (0) 70 71 - 707 0

Fax +49 (0) 70 71 - 707 400

E-mail: sales-motox@flender-motox.com

<http://www.flender.com>

24 h Service Hotline +49 (0) 172 - 7 32 29 55

or to one of our customer-services. The addresses of the customer-services are given in section 12. "Stocking spare parts and customer service addresses".

1.3 Amendments

These amended overall operating instructions replace the individual operating instructions BA G298, BA K298, BA F298, BA F298B and BA S298 including their annexes.

2. Safety instructions

2.1 Intended use

The **MOTOX[®]-N drives** described in these operating instructions have been developed for stationary use in general engineering applications. Unless otherwise agreed, the drives have been designed for use in plant and equipment in industrial environments.

The drives have been manufactured in accordance with the state of the art and are delivered in a condition for safe and reliable use. Any changes on the part of the user which may affect safety and reliability are prohibited.

The drives are designed only for the application described in section 3. "Technical data". They must not be operated outside the specified power limits. Other operating conditions must be contractually agreed.



Drives in ATEX version.

The ATEX drive satisfies the requirements of explosion safety guideline 94/9/EG.

The performance data apply at an ambient temperature of -20 °C to $+40\text{ °C}$.

In the case of drives in ATEX version please observe the instructions marked with this symbol.

2.2 General safety instructions

The drives must be installed, started up, operated, maintained and, if necessary, repaired only by authorised, properly trained and qualified personnel. For definition of expert staff, refer to i.a. IEC 364.

The operator must ensure that all persons involved in installation, operation, maintenance and repair have read and understood these operating instructions and comply with them at all times in order to:

- avoid injury or damage
- ensure the safety and reliability of the drive
- avoid disruptions and environmental damage through incorrect use.

Carry out work on the drives only when they are at a standstill.

Secure the drive units against unintentional starting (e.g. lock key switches or remove fuses in the power supply).

A notice should be attached to the start switch stating clearly that work on the drives is in progress.

Carry out all work with great care and with due regard to safety.

Always observe the instructions on the plates on the drives. The plates must be kept free from paint and dirt at all times. Replace any missing plates.

Ensure compliance with the relevant safety and environmental regulations during transport, assembly and dismantling, operation, and care and maintenance of the unit.

Secure rotating drive parts, e.g. couplings, gears or belt drives, against contact by means of suitable safety devices.

Ensure adequate ventilation when working with solvents. Do not inhale vapours. Do not smoke.

Collect and dispose of used oil in accordance with regulations. Remove any oil spillage immediately with an oil-binding agent in compliance with environmental requirements.

When installing the drives in plant or equipment, the manufacturer of such plant or equipment must ensure that the contents of the present operating instructions are incorporated in his own instructions, information and descriptions.

3. Technical data

3.1 Type designations

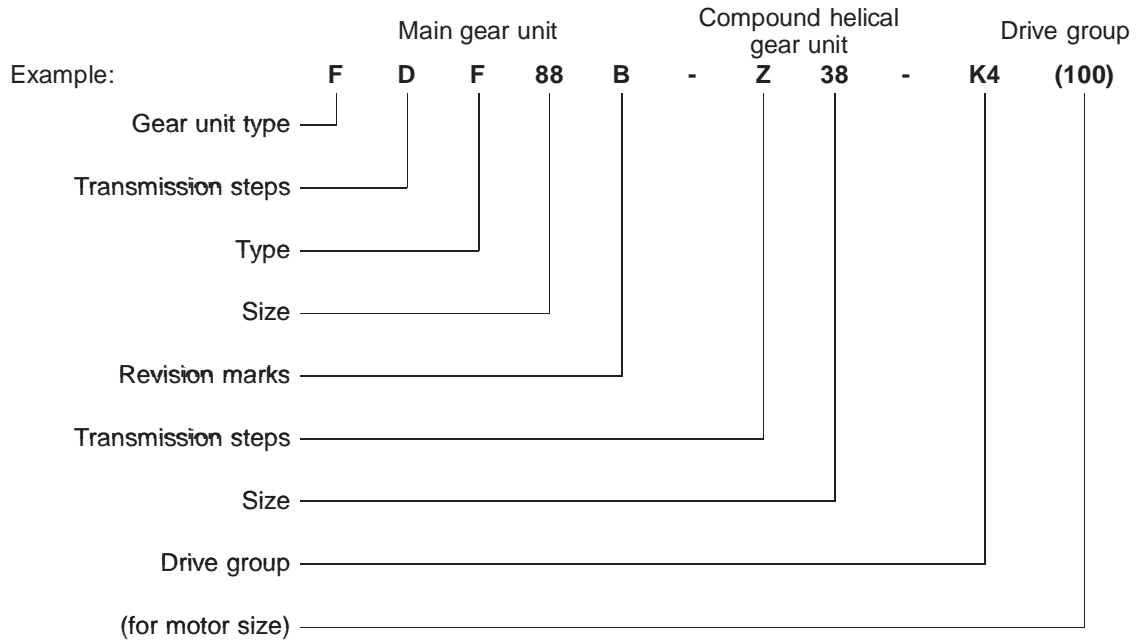

Gear unit type

- (-) Helical gear unit
- K** Bevel helical gear unit
- F** Parallel shaft helical gear unit
- C** Helical worm gear unit

Compound helical gear unit

- Transmission steps**
- Z** two-stage
 - D** three-stage

Transmission steps

- (-) single-stage
- Z** two-stage
- D** three-stage

Drive group

- K4** Bell housing with stub-shaft connection for IEC flanged motors
- K2** Bell housing with flexible coupling for IEC flanged motors
- A** Drive flange with free drive flange
- P** Motor bedplate version

Type

Shaft

- (-) Solid shaft
- A** Hollow shaft

Fixing

- (-) Foot-mounted design
- F** Flanged version (A-type)
- Z** Housing flange (C-type)
- D** Torque arm
- G** Flange (A-type) opposite output shaft
- R** Agitator flange
- M** Agitator / mixer flange
- E** Extruder flange

Connection

- (-) Parallel key
- S** Shrink disc
- T** Hollow shaft with splines

Backstop

- X** Backstop in intermediate stage

3.2 General technical data

The most important technical data are shown on the rating plate of the gear units of gear motors. These data together with the contractual agreements on the drive units determine the limits of its proper use.

In the case of gear motors a rating plate attached to the motor serves for the entire drive.

In certain cases separate rating plates are attached to the gear unit and the motor.

Examples: Rating plate - gear motor

Rating plate - gear unit

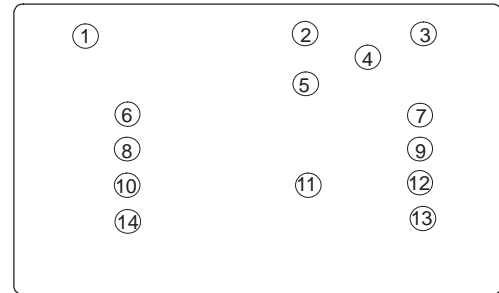
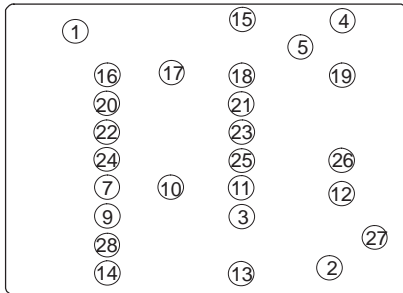



Figure 3.2–1: Rating plate

- | | | | |
|----|--|----|---|
| 1 | Company logo | 15 | Phase number and type of current of the motor |
| 2 | Manufacturing date encoded | 16 | Switch symbols to DIN EN 60617 T6 / IEC 617-6 |
| 3 | Weight m [kg] | 18 | Rating voltage U [V] |
| 4 | Order no. / seq. no. | 18 | Rating current I [A] |
| 5 | Model - Type - Size | 19 | Rating frequency f [Hz] |
| 6 | Performance rating T_2 [Nm] | 20 | Rating speed n [min^{-1}] |
| 7 | Mounting position | 21 | Rating performance P [kW] |
| 8 | Total transmission ratio i | 22 | Operating mode (if \neq S1) |
| 9 | Speed n_2 [min^{-1}] | 23 | Performance factor $\cos \varphi$ |
| 10 | Type of oil | 24 | Type of protection to IEC 60034-5 or IEC 529 |
| 11 | Oil viscosity ISO VG class to DIN 51519 / ISO 3448 | 25 | Heat class Th. Cl. |
| 12 | Oil quantity [l] Main gear unit / ancillary transmission+extruder flange | 26 | applied standard |
| 13 | Free space for additional data | 27 | CE-marking or other marking, if any |
| 14 | max. ambient temperature TU_{max} [$^{\circ}\text{C}$] | 28 | Brake data |

Symbols (IEC 617-2):  = Brake
 = Coupling



Drives in ATEX version.
Example: Rating plate



Figure 3.2–2: Rating plate ATEX version



- | | |
|--|---|
| <ol style="list-style-type: none"> 1 Type designation 2 Mounting position, order number 3 Output speed n_2 [min^{-1}] Output torque T_2 [Nm] Transmission ratio i Duty factor Input speed n_1 [min^{-1}] Input torque T_1 [Nm] | <ol style="list-style-type: none"> 4 Explosion-hazard symbol and explosion-hazard marking, CE-marking 5 Oil quantity [l] Type of oil Weight m [kg] 6 Space for additional information |
|--|---|

3.3 Weights

The weight of the overall drive including motor is indicated on the rating plate of the gear unit or gear motor, if it exceeds 30 kg; in each case it is shown in the delivery documents.

Where there are several rating plates on one drive, the specification on the main gear unit is decisive.

The weight specification refers only to the condition on delivery of the products.

3.4 Sound-pressure level

The A-assessed sound-pressure levels L_{WA} of a selection of gear units in figure 3.4 “Sound-pressure level” have been measured to DIN EN 21680, using measuring instruments to DIN IEC 651.

The noise depends mainly on speed, output and transmission ratio.

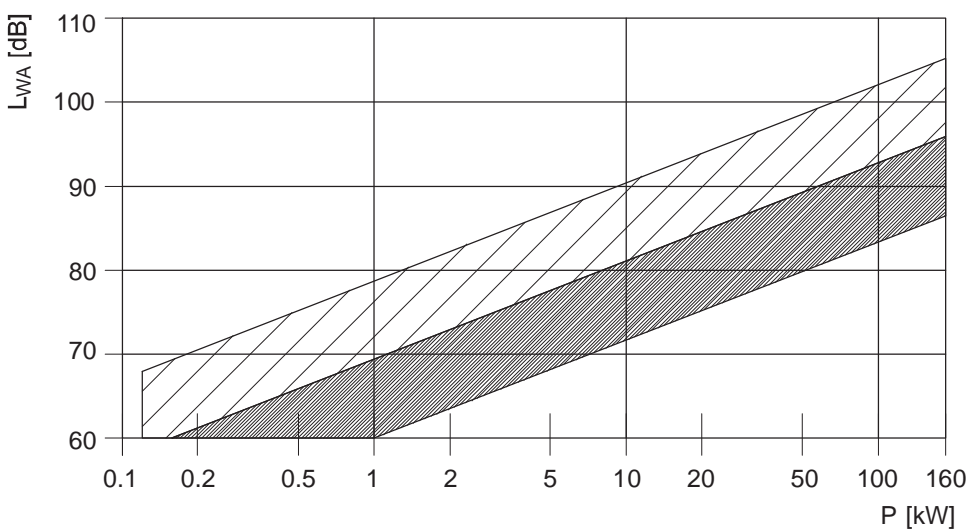

Figure 3.4: Sound-pressure level

The sound-pressure levels of **MOTOX®-N gear motors** fall mainly in the dark-coloured part of the range. Gear units with very small transmission ratios, high output and high input speed may fall in the cross-hatched part.

If repeat measurements on site do not produce conclusive results with regard to measuring technology, the measurement obtained on the **FLENDER TÜBINGEN GMBH** test bench will apply.

External noises

Noises not generated by the gear unit but emitted from it are not taken into consideration here.

Likewise noises emitted from the prime mover and output machines and from the foundation are not taken into consideration here, even if transmitted to these by the gear unit.

3.5 Mounting positions

The assembly option designations are in accordance with IEC 60034-7 (Code I).

The drives must be operated only in the assembly option specified on the rating plate. This ensures that the correct quantity of lubricant is provided

Identification marking:



Oil level



Housing ventilation



Oil drain plug



Oil dipstick

A,B Position of stub-shaft and / or solid shaft

V Gear units of size 38 are standard-fitted with a screw plug at point "V". Ventilation is not required.

* on opposite side

② two-stage gear unit

③ three-stage gear unit

④ Tandem gear unit

— — — alternative

3.5.1 One-stage helical gear units



Note.
For key to diagram symbols, see section 3.5 "Mounting positions".

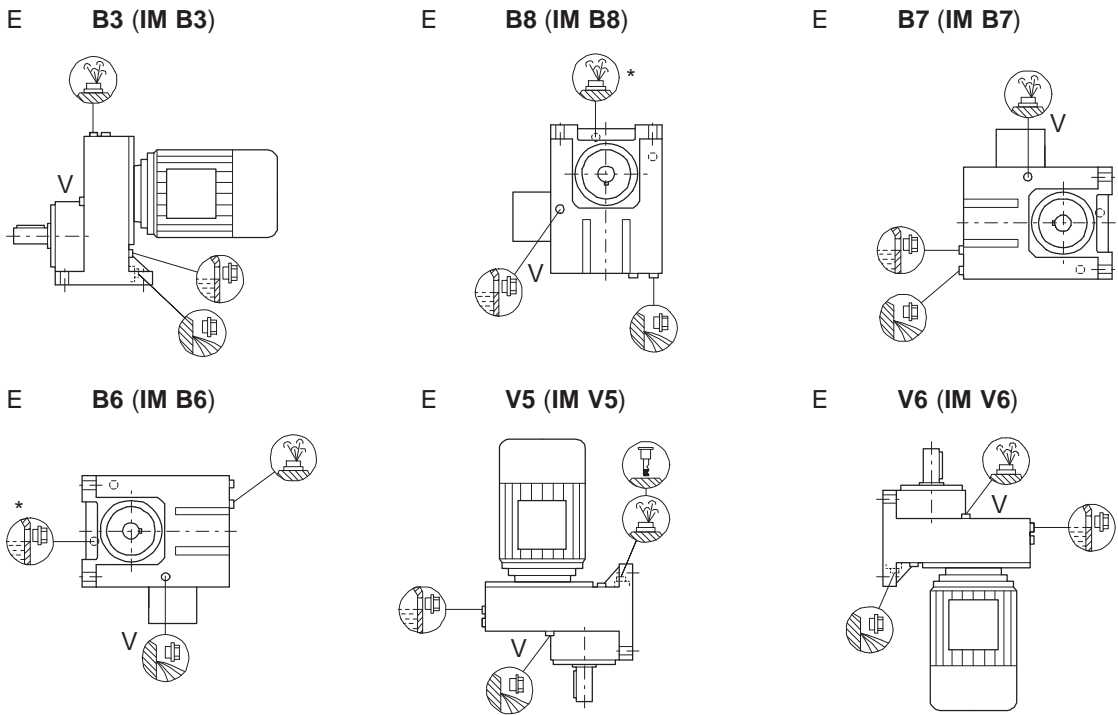

Figure 3.5.1–1: Mounting positions for E38 - E148

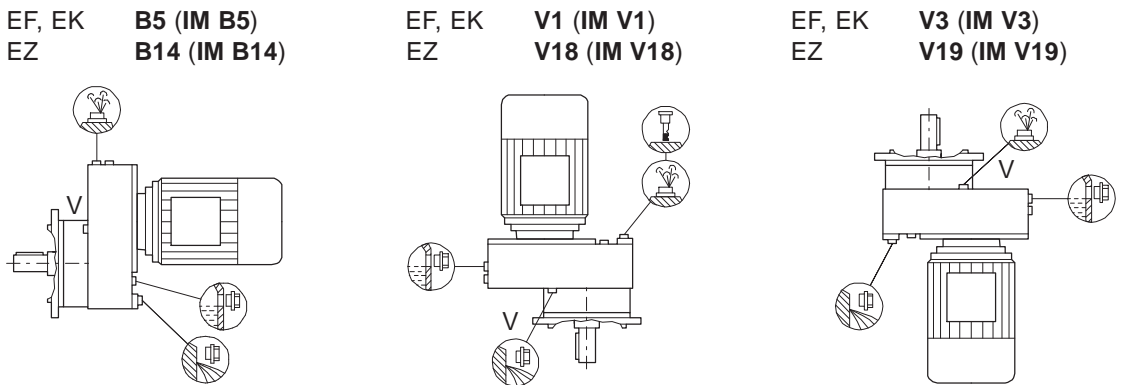

Figure 3.5.1–2: Mounting positions for E.38 - E.148

3.5.2 Two and three-stage helical gear units



Note.
For key to diagram symbols, see section 3.5 "Mounting positions".

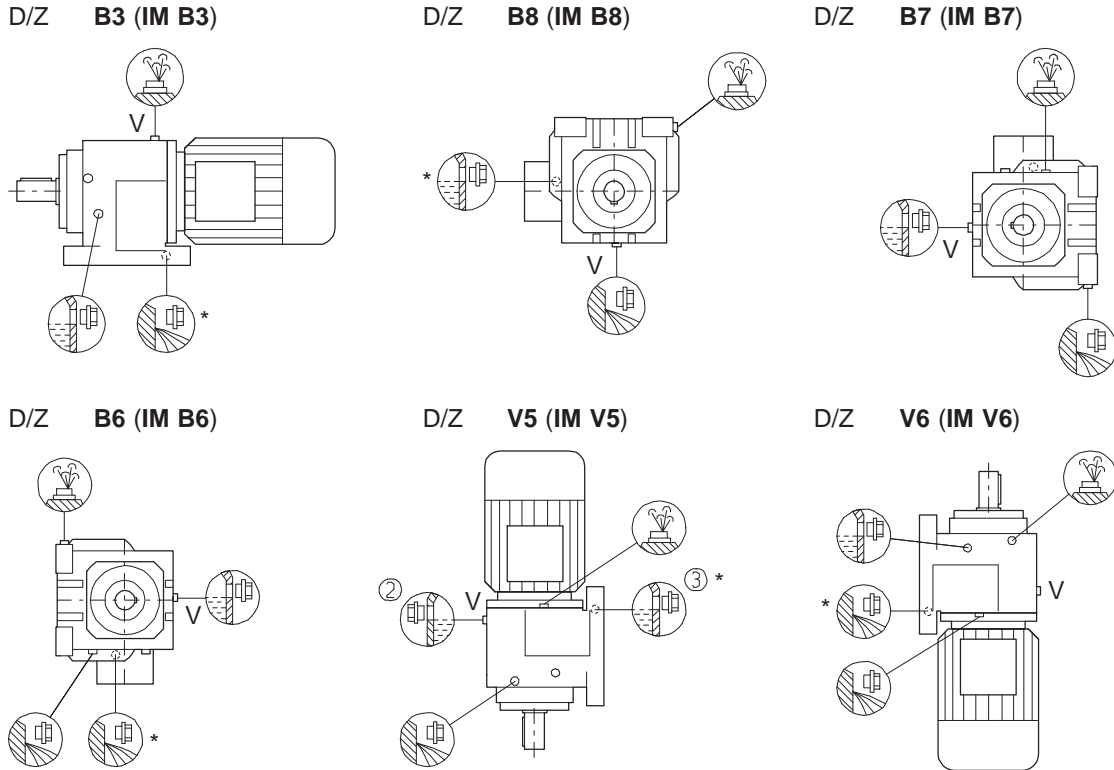

Figure 3.5.2-1: Mounting positions for D/Z38 - D/Z88

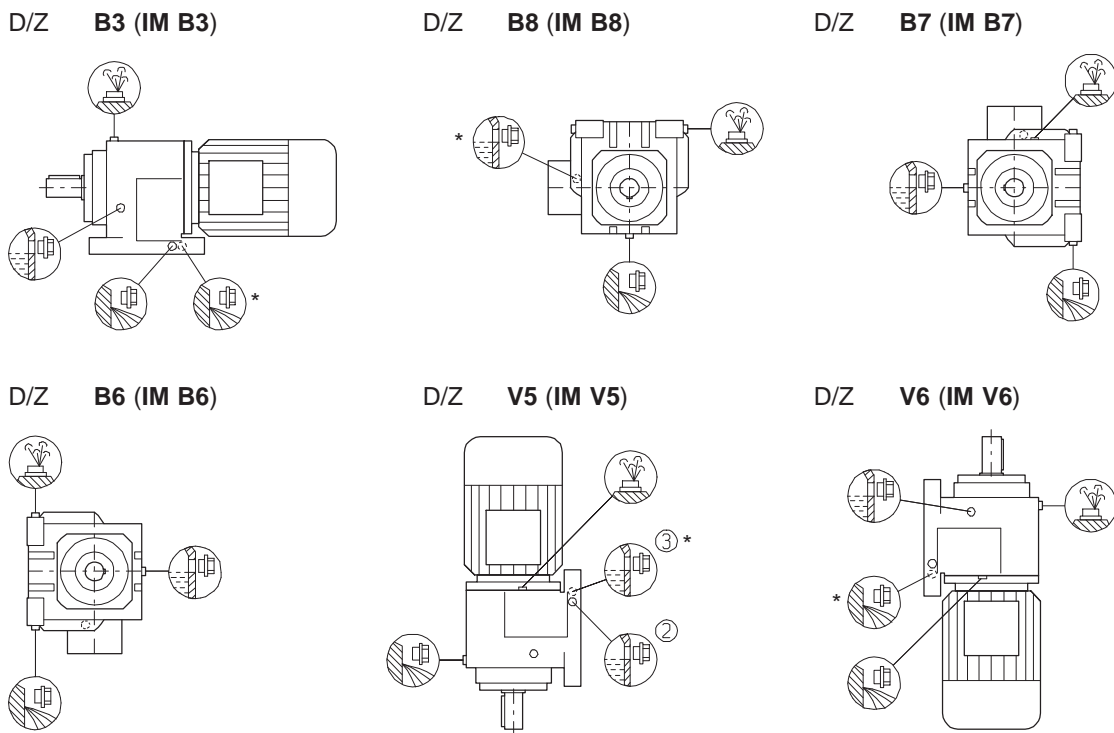

Figure 3.5.2-2: Mounting positions for D/Z108 - D/Z168



Note.

For key to diagram symbols, see section 3.5 "Mounting positions".

D/Z **B3 (IM B3)**

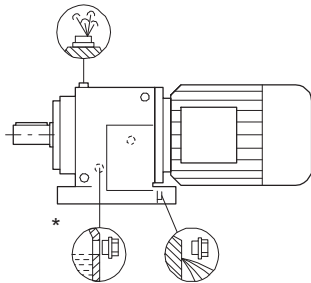

D/Z **B8 (IM B8)**

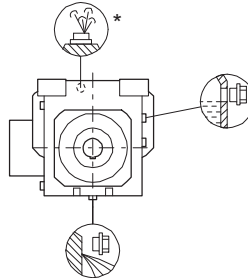

D/Z **B7 (IM B7)**

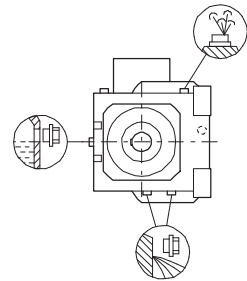

D/Z **B6 (IM B6)**

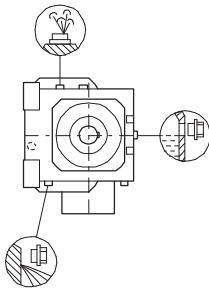

D/Z **V5 (IM V5)**

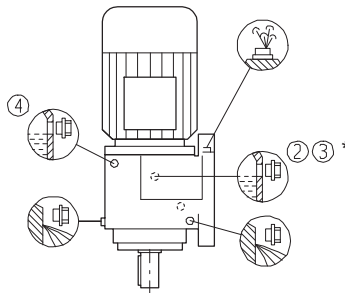

D/Z **V6 (IM V6)**

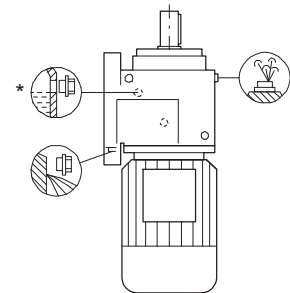
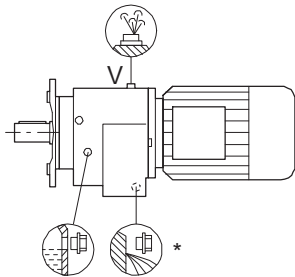
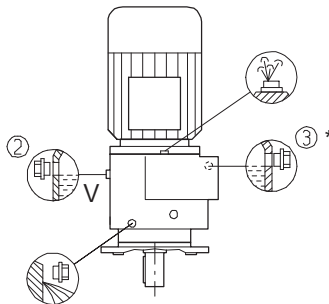

Figure 3.5.2–3: Mounting positions for D/Z188

ZK, DF/ZF **B5 (IM B5)**
DZ/ZZ **B14 (IM B14)**



ZK, DF/ZF **V1 (IM V1)**
DZ/ZZ **V18 (IM V18)**



ZK, DF/ZF **V3 (IM V3)**
DZ/ZZ **V19 (IM V19)**

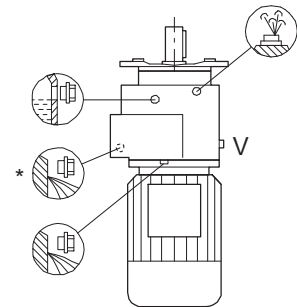
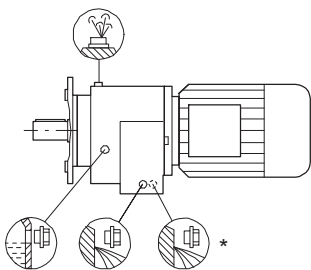
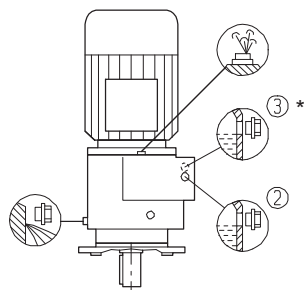

Figure 3.5.2–4: Mounting positions for D./Z.38 - D./Z.88

ZK, DF/ZF **B5 (IM B5)**
DZ/ZZ **B14 (IM B14)**



ZK, DF/ZF **V1 (IM V1)**
DZ/ZZ **V18 (IM V18)**



ZK, DF/ZF **V3 (IM V3)**
DZ/ZZ **V19 (IM V19)**

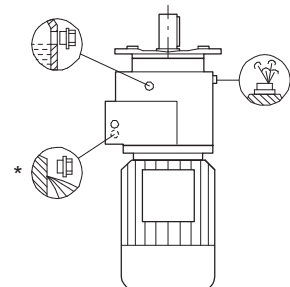

Figure 3.5.2–5: Mounting positions for D./Z.108 - D./Z.168



Note.

For key to diagram symbols, see section 3.5 "Mounting positions".

ZK, DF/ZF **B5 (IM B5)**
DZ/ZZ **B14 (IM B14)**

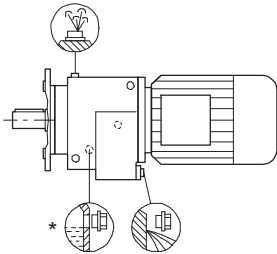

ZK, DF/ZF **V1 (IM V1)**
DZ/ZZ **V18 (IM V18)**

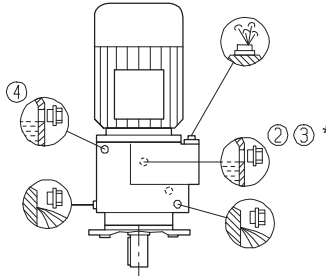

ZK, DF/ZF **V3 (IM V3)**
DZ/ZZ **V19 (IM V19)**

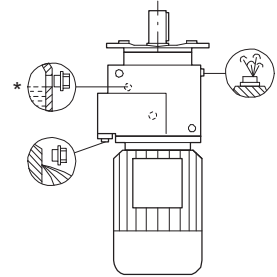
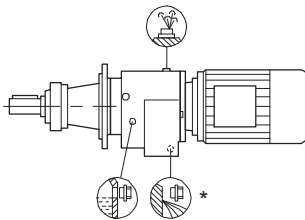
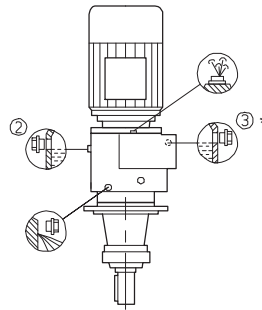

Figure 3.5.2-6: Mounting positions for D./Z.188

DR/ZR **B5 (IM B5)**



DR/ZR **V1 (IM V1)**



DR/ZR **V3 (IM V3)**

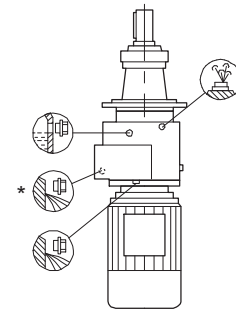
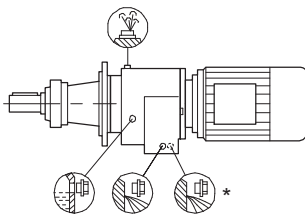
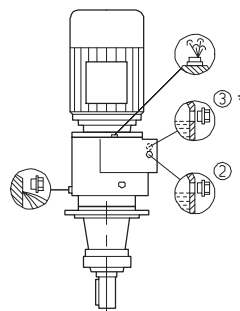

Figure 3.5.2-7: Mounting positions for DR/ZR68 - DR/ZR88

DR/ZR **B5 (IM B5)**



DR/ZR **V1 (IM V1)**



DR/ZR **V3 (IM V3)**

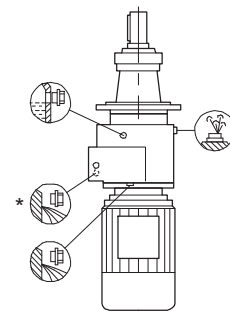

Figure 3.5.2-8: Mounting positions for DR/ZR108 - DR/ZR168

3.5.3 Bevel-helical gear units



Note.
For key to diagram symbols, see section 3.5 "Mounting positions".

The assembly options shown apply also to the foot/flange-mounted housing, size 188.

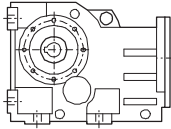
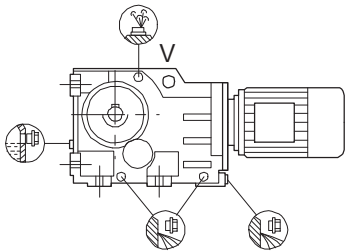
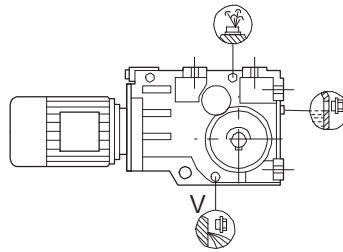

Figure 3.5.3–1: Presentation - foot/flange housing K.188

K **B3-00 (IM B3-00)**
KA. **H-01**



K **B8-00 (IM B8-00)**
KA. **H-02**



K **B7-00 (IM B7-00)**
KA. **H-03**

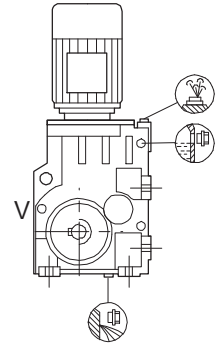

K **B6-00 (IM B6-00)**
KA. **H-04**

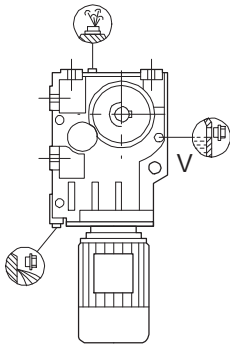

K **V5-00 (IM V5-00)**
KA. **H-05**

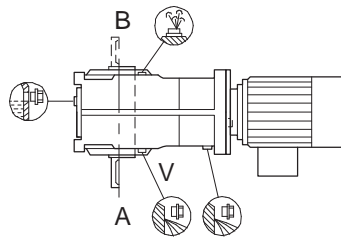

K **V6-00 (IM V6-00)**
KA. **H-06**

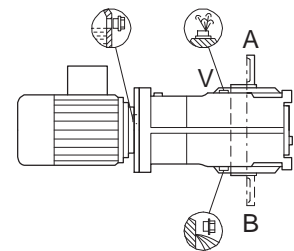

Figure 3.5.3–2: Mounting positions for K, KA, KAS, KAT Size 38 - 188



Note.

For key to diagram symbols, see section 3.5 "Mounting positions".

KZ, KF **B5-01 (IM B5-01)**
KA. **H-01**

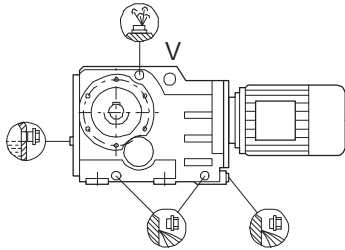

KZ, KF **B5-03 (IM B5-03)**
KA. **H-02**

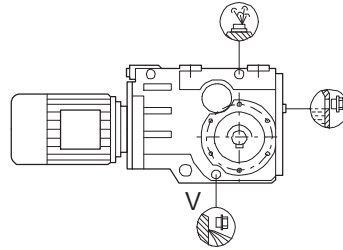

KZ, KF **B5-02 (IM B5-02)**
KA. **H-03**

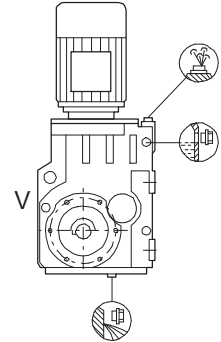

KZ, KF **B5-00 (IM B5-00)**
KA. **H-04**

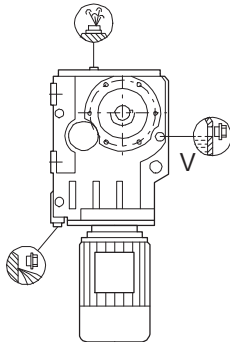

KZ, KF **V1-00 (IM V1-00)**
KA. **H-05**

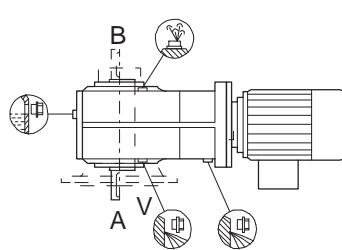

KZ, KF **V3-00 (IM V3-00)**
KA. **H-06**

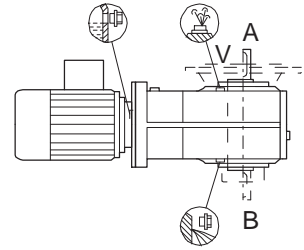

Figure 3.5.3–3: Mounting positions for KZ, KF, KAD, KAF, KAZ, KADS, KAFS, KAZS, KADT, KAFT, KAZT Size 38 - 188

3.5.4 Parallel shaft helical gear units



Note.

For key to diagram symbols, see section 3.5 "Mounting positions".

F.Z, F.F **B5-01 (IM B5-01)**
F.A. **H-01**

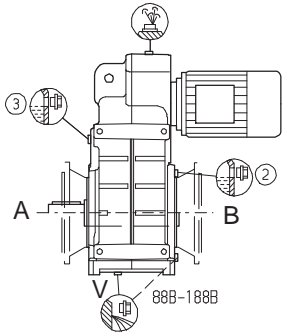

F.Z, F.F **B5-03 (IM B5-03)**
F.A. **H-02**

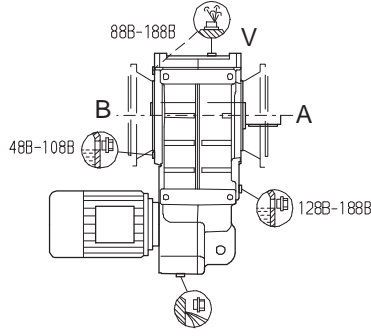

F.Z, F.F **B5-02 (IM B5-02)**
F.A. **H-03**

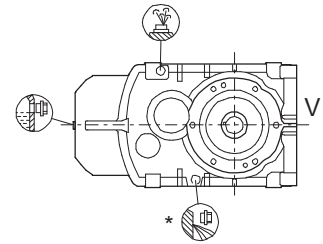

F.Z, F.F **B5-00 (IM B5-00)**
F.A. **H-04**

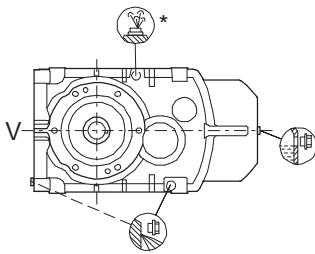

F.Z, F.F **V1-00 (IM V1-00)**
F.A. **H-05**

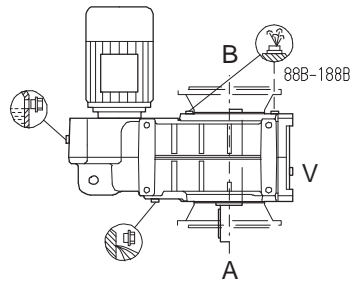

F.Z, F.F **V3-00 (IM V3-00)**
F.A. **H-06**

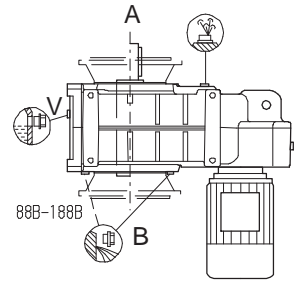

Figure 3.5.4: Mounting positions for F.38B - F.188B

3.5.5 Helical worm gear units



Note.

For key to diagram symbols, see section 3.5 "Mounting positions".

C **B3-00 (IM B3-00)**
CA. **H-01**

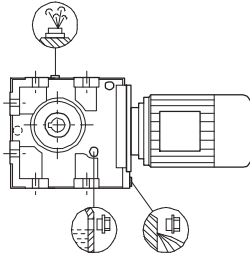

C **B8-00 (IM B8-00)**
CA. **H-02**

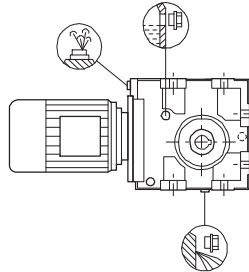

C **B7-00 (IM B7-00)**
CA. **H-03**

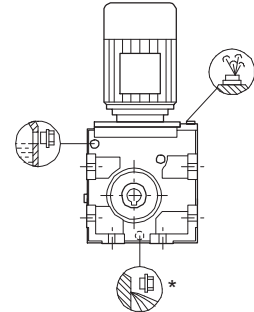

C **B6-00 (IM B6-00)**
CA. **H-04**

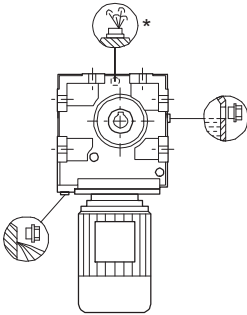

C **V5-00 (IM V5-00)**
CA. **H-05**

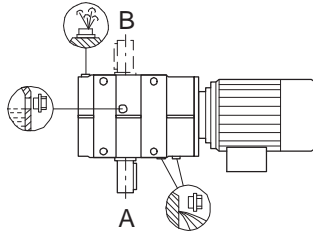

C **V6-00 (IM V6-00)**
CA. **H-06**

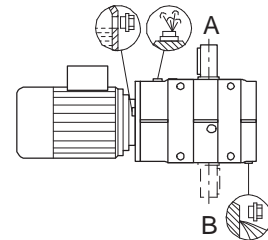
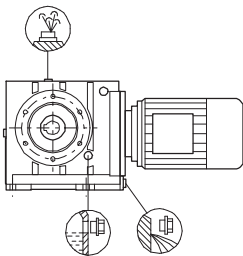
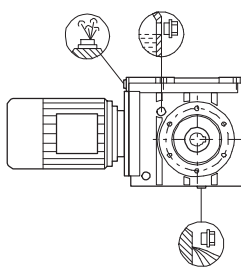

Figure 3.5.5–1: Mounting positions for C, CA, CAS, CAT Size 38 - 88

CZ, CF **B5-01 (IM B5-01)**
CA. **H-01**



CZ, CF **B5-03 (IM B5-03)**
CA. **H-02**



CZ, CF **B5-02 (IM B5-02)**
CA. **H-03**

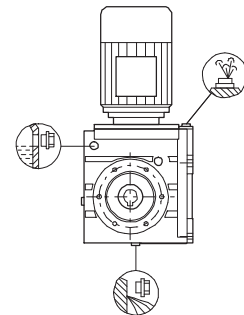

CZ, CF **B5-00 (IM B5-00)**
CA. **H-04**

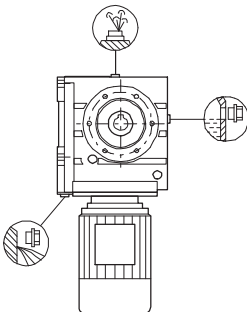

CZ, CF **V1-00 (IM V1-00)**
CA. **H-05**

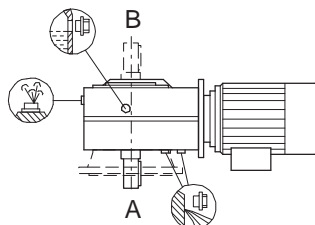

CZ, CF **V3-00 (IM V3-00)**
CA. **H-06**

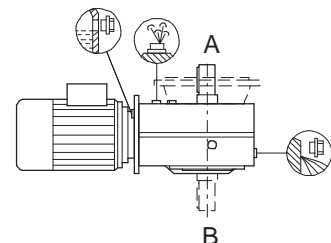

Figure 3.5.5–2: Mounting positions for CZ, CF, CAD, CAF, CAZ, CADS, CAFS, CAZS, CADT, CAFT, CAZT Size 38 - 88

3.5.6 Tandem gear unit - compound helical gear unit



Note.

In a horizontal operating position the bulging part of the housing of the 2nd gear unit generally faces downwards.

Types Z.28 are standard-fitted with three screw plugs.

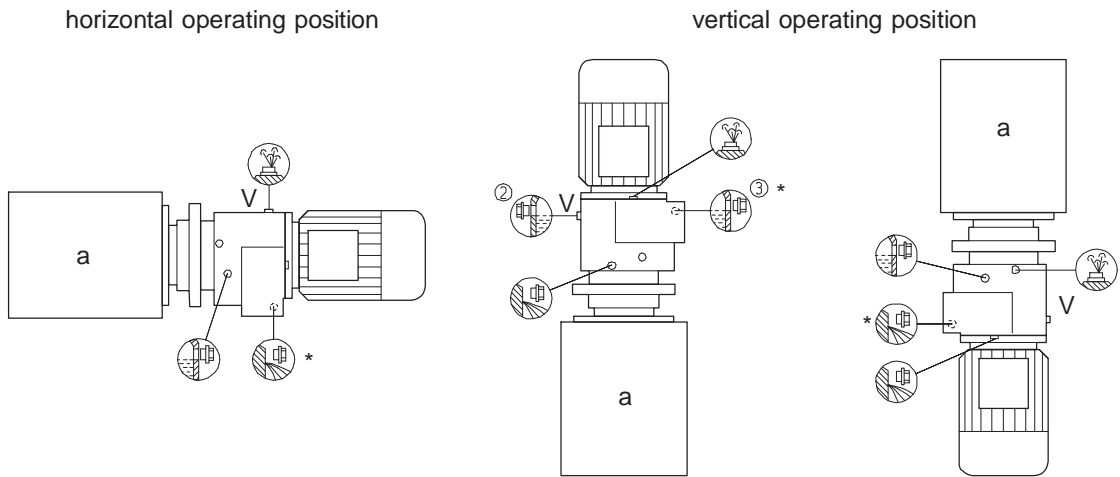

Figure 3.5.6: Operating position for dual gear unit

a Main gear unit

3.6 Oil quantities



Caution.

Incorrect oil quantities cause damage to the drive.
The exact oil quantities are specified on the rating plates of the drives.
The oil quantities listed in the tables are approximate values. They serve for the storage and procurement of lubricant.

3.6.1 Helical gear units

| Type | Mounting position | | | | | | | | |
|-------|-------------------|-----------|------|------|------|-----------|-----------|------|------|
| | B3 | B5 B14 | B6 | B7 | B8 | V1 V18 | V3 V19 | V5 | V6 |
| E.38 | 0.2 | 0.2 | 0.3 | 0.3 | 0.4 | 0.5 | 0.6 | 0.5 | 0.6 |
| E.48 | 0.3 | 0.3 | 0.6 | 0.5 | 0.7 | 0.7 | 1.1 | 0.7 | 1.1 |
| E.68 | 0.5 | 0.5 | 1.0 | 1.1 | 1.5 | 1.7 | 1.9 | 1.8 | 1.9 |
| E.88 | 0.8 | 0.7 | 1.6 | 1.6 | 2.5 | 2.2 | 3.8 | 2.3 | 3.8 |
| E.108 | 1.3 | 1.0 | 2.7 | 2.8 | 4.6 | 3.7 | 6.6 | 3.8 | 6.6 |
| E.128 | 2.3 | 2.3 | 5.3 | 5.2 | 7.2 | 6.4 | 10.9 | 6.4 | 10.9 |
| E.148 | 4.0 | 2.8 | 7.0 | 7.0 | 10.3 | 9.3 | 14.5 | 9.5 | 14.8 |
| Z.38 | 0.5 | 0.5 | 0.6 | 0.6 | 0.6 | 0.8 | 1.2 | 0.7 | 1.1 |
| Z.48 | 1.1 | 1.0 | 1.6 | 1.3 | 1.5 | 1.8 | 2.4 | 1.9 | 2.4 |
| Z.68 | 1.8 | 1.7 | 2.7 | 2.3 | 2.5 | 3.0 | 4.1 | 3.2 | 4.1 |
| Z.88 | 4.1 | 3.7 | 6.1 | 5.3 | 5.7 | 6.8 | 8.3 | 7.5 | 8.8 |
| Z.108 | 7.3 | 6.0 | 10.5 | 9.3 | 8.6 | 13.8 | 14.0 | 13.2 | 13.6 |
| Z.128 | 9.5 | 7.0 | 16.0 | 14.1 | 13.2 | 18.5 | 20.7 | 19.9 | 20.9 |
| Z.148 | 13.0 | 9.9 | 20.8 | 18.3 | 26.9 | 23.9 | 27.7 | 25.7 | 27.4 |
| Z.168 | 21.0 | 15.3 | 34.8 | 30.1 | 32.1 | 48.0 | 31.1 | 48.0 | 41.7 |
| Z.188 | 18.5 | 18.5 | 50.0 | 46.0 | 75.0 | 72.0 | 70.0 | 72.0 | 70.0 |
| D.38 | 0.5 | 0.5 | 0.6 | 0.6 | 0.6 | 0.9 | 1.1 | 0.9 | 1.1 |
| D.48 | 1.1 | 1.0 | 1.5 | 1.4 | 1.5 | 2.3 | 2.4 | 2.4 | 2.4 |
| D.68 | 1.7 | 1.6 | 2.6 | 2.4 | 2.6 | 3.9 | 4.0 | 4.0 | 4.0 |
| D.88 | 4.0 | 3.6 | 5.9 | 5.4 | 5.9 | 8.7 | 8.9 | 9.3 | 8.9 |
| D.108 | 7.1 | 5.7 | 10.3 | 9.5 | 10.0 | 16.3 | 14.2 | 15.6 | 13.7 |
| D.128 | 9.4 | 6.8 | 15.8 | 14.8 | 14.1 | 24.6 | 21.8 | 24.4 | 21.5 |
| D.148 | 12.5 | 9.4 | 20.4 | 19.1 | 23.4 | 30.6 | 28.2 | 32.2 | 27.9 |
| D.168 | 19.0 | 16.0 | 34.1 | 31.2 | 33.8 | 53.0 | 43.7 | 54.4 | 42.2 |
| D.188 | 18.4 | 18.4 | 48.0 | 46.0 | 73.0 | 69.0 | 68.0 | 69.0 | 68.0 |

Table 3.6.1: Oil quantities for E.38 - E.148, D./Z.38 - D./Z.188

3.6.2 Bevel-helical gear units

| Type | Mounting position | | | | | |
|-------|-------------------|---------------|---------------|---------------|---------------|---------------|
| | B3-00 H-01 | B8-00 H-02 | B7-00 H-03 | B6-00 H-04 | V5-00 H-05 | V6-00 H-06 |
| K.38 | 0.5 | 1.1 | 1.4 | 0.8 | 1.0 | 0.9 |
| K.48 | 0.7 | 1.6 | 2.0 | 1.4 | 1.5 | 1.8 |
| K.68 | 1.6 | 3.2 | 3.9 | 2.7 | 3.0 | 3.0 |
| K.88 | 2.6 | 5.7 | 7.4 | 5.0 | 4.9 | 5.2 |
| K.108 | 5.5 | 9.5 | 12.6 | 8.8 | 8.7 | 8.3 |
| K.128 | 8.3 | 19.6 | 24.4 | 15.8 | 16.9 | 16.1 |
| K.148 | 14.8 | 30.2 | 37.0 | 22.0 | 25.8 | 27.0 |
| K.168 | 21.6 | 45.6 | 60.5 | 34.2 | 40.2 | 38.5 |
| K.188 | 33.8 | 82.5 | 104.2 | 63.4 | 70.7 | 69.4 |

Table 3.6.2–1: Oil quantities for K, KA, KAS, KAT Size 38 - 188

| Type | Mounting position | | | | | |
|-------|-------------------|---------------|---------------|---------------|---------------|---------------|
| | B5-01 H-01 | B5-03 H-02 | B5-02 H-03 | B5-00 H-04 | V1-00 H-05 | V3-00 H-06 |
| K.38 | 0.5 | 1.1 | 1.5 | 0.8 | 1.0 | 0.9 |
| K.48 | 0.7 | 1.7 | 2.0 | 1.4 | 1.6 | 1.8 |
| K.68 | 1.6 | 3.2 | 3.9 | 2.6 | 2.8 | 3.0 |
| K.88 | 2.6 | 5.8 | 7.7 | 5.0 | 5.1 | 5.0 |
| K.108 | 6.2 | 9.9 | 13.7 | 8.9 | 10.0 | 8.9 |
| K.128 | 8.7 | 19.6 | 25.0 | 14.8 | 17.5 | 16.6 |
| K.148 | 14.8 | 30.1 | 41.0 | 25.0 | 26.0 | 28.1 |
| K.168 | 21.7 | 46.3 | 62.6 | 34.8 | 41.1 | 39.4 |
| K.188 | 33.8 | 82.5 | 104.5 | 63.4 | 70.7 | 69.4 |

Table 3.6.2–2: Oil quantities for KZ, KF, KAD, KAF, KAZ, KADS, KAFS, KAZS, KADT, KAFT, KAZT Size 38 - 188

3.6.3 Parallel shaft helical gear units

| Type | Mounting position | | | | | |
|---------|-------------------|---------------|---------------|---------------|---------------|---------------|
| | B5-01 H-01 | B5-03 H-02 | B5-02 H-03 | B5-00 H-04 | V1-00 H-05 | V3-00 H-06 |
| FZ.38B | 0.7 | 0.6 | 0.7 | 0.7 | 1.0 | 1.1 |
| FZ.48B | 1.6 | 1.0 | 1.3 | 1.3 | 1.8 | 2.1 |
| FZ.68B | 2.5 | 2.3 | 2.4 | 2.3 | 3.3 | 3.8 |
| FZ.88B | 4.5 | 5.0 | 4.8 | 4.6 | 7.0 | 6.6 |
| FZ.108B | 7.4 | 9.2 | 8.4 | 8.1 | 11.1 | 13.1 |
| FZ.128B | 13.8 | 13.7 | 15.5 | 14.8 | 22.1 | 22.7 |
| FZ.148B | 19.5 | 20.8 | 22.7 | 22.3 | 34.5 | 33.5 |
| FZ.168B | 32.8 | 30.0 | 37.0 | 35.8 | 53.8 | 53.0 |
| FZ.188B | 41.4 | 40.7 | 44.2 | 46.5 | 68.0 | 66.4 |
| FD.38B | 0.9 | 0.6 | 0.7 | 0.7 | 0.9 | 1.1 |
| FD.48B | 2.0 | 0.9 | 1.3 | 1.3 | 1.8 | 2.0 |
| FD.68B | 3.3 | 2.3 | 2.4 | 2.3 | 3.2 | 3.8 |
| FD.88B | 6.3 | 5.0 | 4.7 | 4.7 | 6.8 | 6.7 |
| FD.108B | 10.6 | 9.1 | 8.2 | 8.2 | 11.1 | 13.0 |
| FD.128B | 16.8 | 13.5 | 15.2 | 14.8 | 21.6 | 22.5 |
| FD.148B | 24.7 | 20.3 | 21.8 | 22.3 | 33.6 | 32.6 |
| FD.168B | 44.0 | 28.8 | 36.0 | 35.8 | 52.4 | 51.9 |
| FD.188B | 52.0 | 38.4 | 44.5 | 45.1 | 66.0 | 65.2 |

Table 3.6.3: Oil quantities for F.38B - F.188B

3.6.4 Helical worm gear units

| Type | Mounting position | | | | | |
|------|-------------------|---------------|---------------|---------------|---------------|---------------|
| | B3-00 H-01 | B8-00 H-02 | B7-00 H-03 | B6-00 H-04 | V5-00 H-05 | V6-00 H-06 |
| C.38 | 0.5 | 1.2 | 1.3 | 1.2 | 1.2 | 1.2 |
| C.48 | 0.7 | 1.6 | 1.7 | 1.6 | 1.3 | 1.3 |
| C.68 | 1.5 | 3.3 | 4.1 | 3.3 | 2.8 | 2.9 |
| C.88 | 1.7 | 6.1 | 6.5 | 5.1 | 4.5 | 4.5 |

Table 3.6.4–1: Oil quantities for C, CA, CAS, CAT Size 38 - 88

| Type | Mounting position | | | | | |
|------|-------------------|---------------|---------------|---------------|---------------|---------------|
| | B5-01 H-01 | B5-03 H-02 | B5-02 H-03 | B5-00 H-04 | V1-00 H-05 | V3-00 H-06 |
| C.38 | 0.4 | 1.2 | 1.3 | 1.1 | 1.0 | 1.0 |
| C.48 | 0.5 | 1.7 | 1.8 | 1.6 | 1.3 | 1.3 |
| C.68 | 1.5 | 3.6 | 4.2 | 3.3 | 3.1 | 3.2 |
| C.88 | 1.7 | 6.6 | 7.3 | 5.2 | 4.8 | 4.8 |

Table 3.6.4–2: Oil quantities for CZ, CF, CAD, CAF, CAZ, CADS, CAFS, CAZS, CADT, CAFT, CAZT Size 38 - 88

3.6.5 Tandem gear unit - compound helical gear unit

3.6.5.1 Two and three-stage helical gear units

| Type | Mounting position | | | | | | | | |
|--------------------|-------------------------|-------------------------|-------------------------|-------------------------|-------------------------|-------------------------|-------------------------|-------------------------|-------------------------|
| | B3 | B5 B14 | B6 | B7 | B8 | V1 V18 | V3 V19 | V5 | V6 |
| Z.38 - Z28 | 0.5+0.3 0.8 | 0.5+0.3 0.8 | 0.6+0.3 0.9 | 0.6+0.3 0.9 | 0.6+0.3 0.9 | 0.7+0.8 1.5 | 1.2+0.8 2.0 | 0.7+0.8 1.5 | 1.1+0.8 1.9 |
| Z.48 - Z28 | 1.1+0.3 1.4 | 1.0+0.3 1.3 | 1.6+0.3 1.9 | 1.3+0.3 1.6 | 1.5+0.3 1.8 | 1.8+0.8 2.6 | 2.4+0.8 3.2 | 1.9+0.8 2.7 | 2.4+0.8 3.2 |
| Z.68 - Z28 | 1.8+0.3 2.1 | 1.8+0.3 2.1 | 2.7+0.3 3.0 | 2.3+0.3 2.6 | 2.5+0.3 2.8 | 3.0+0.8 3.8 | 4.1+0.8 4.9 | 3.2+0.8 4.0 | 4.1+0.8 4.9 |
| Z.68 - Z38 | 1.8+0.5 2.3 | 1.8+0.5 2.3 | 2.7+0.5 3.2 | 2.3+0.5 2.8 | 2.5+0.5 3.0 | 3.0+0.8 3.8 | 4.1+1.2 5.3 | 3.2+0.7 3.9 | 4.1+1.2 5.3 |
| D.38 - Z28 | 0.5+0.3 0.8 | 0.5+0.3 0.8 | 0.6+0.3 0.9 | 0.6+0.3 0.9 | 0.6+0.3 0.9 | 0.9+0.8 1.7 | 1.1+0.8 1.9 | 0.9+0.8 1.7 | 1.1+0.8 1.9 |
| D.48 - Z28 | 1.1+0.3 1.4 | 1.0+0.3 1.3 | 1.5+0.3 1.8 | 1.4+0.3 1.7 | 1.5+0.3 1.8 | 2.3+0.8 3.1 | 2.4+0.8 3.2 | 2.4+0.8 3.2 | 2.4+0.8 3.2 |
| D.68 - Z28 | 1.7+0.3 2.0 | 1.6+0.3 1.9 | 2.6+0.3 2.9 | 2.4+0.3 2.7 | 2.6+0.3 2.9 | 3.9+0.8 4.7 | 4.0+0.8 4.8 | 4.0+0.8 4.8 | 4.0+0.8 4.8 |
| D.68 - Z38 | 1.7+0.5 2.2 | 1.6+0.5 2.1 | 2.6+0.5 3.1 | 2.4+0.5 2.9 | 2.6+0.5 3.1 | 3.9+0.8 4.7 | 4.0+1.2 5.2 | 4.0+0.7 4.7 | 4.0+1.2 5.2 |
| D.68 - D38 | 1.7+0.5 2.2 | 1.6+0.5 2.1 | 2.6+0.5 3.1 | 2.4+0.5 2.9 | 2.6+0.5 3.1 | 3.9+0.9 4.8 | 4.0+1.1 5.1 | 4.0+0.9 4.9 | 4.0+1.1 5.1 |
| D.88 - Z28 | 4.0+0.3 4.3 | 3.6+0.3 3.9 | 5.9+0.3 6.2 | 5.4+0.3 5.7 | 5.9+0.3 6.2 | 8.7+0.8 9.5 | 8.9+0.8 9.7 | 9.3+0.8 10.1 | 8.9+0.8 9.7 |
| D.88 - Z38 | 4.0+0.5 4.5 | 3.6+0.5 4.1 | 5.9+0.5 6.4 | 5.4+0.5 5.9 | 5.9+0.5 6.4 | 8.7+0.8 9.5 | 8.9+1.2 10.1 | 9.3+0.7 10.0 | 8.9+1.2 10.1 |
| D.88 - D38 | 4.0+0.5 4.5 | 3.6+0.5 4.1 | 5.9+0.5 6.4 | 5.4+0.5 5.9 | 5.9+0.5 6.4 | 8.7+0.9 9.6 | 8.9+1.1 10.0 | 9.3+0.9 10.2 | 8.9+1.1 10.0 |
| D.108 - Z28 | 7.1+0.3 7.4 | 5.7+0.3 6.0 | 10.3+0.3 10.6 | 9.5+0.3 9.8 | 10.0+0.3 10.3 | 16.3+0.8 17.1 | 14.2+0.8 15.0 | 15.6+0.8 16.4 | 13.7+0.8 14.5 |
| D.108 - Z38 | 7.1+0.5 7.6 | 5.7+0.5 6.2 | 10.3+0.5 10.8 | 9.5+0.5 10.0 | 10.0+0.5 10.5 | 16.3+0.8 17.1 | 14.2+1.2 15.4 | 15.6+0.7 16.3 | 13.7+1.2 14.9 |
| D.108 - D38 | 7.1+0.5 7.6 | 5.7+0.5 6.2 | 10.3+0.5 10.8 | 9.5+0.5 10.0 | 10.0+0.5 10.5 | 16.3+0.9 17.2 | 14.2+1.1 15.2 | 15.6+0.9 16.5 | 13.7+1.1 14.8 |
| D.128 - Z28 | 9.4+0.3 9.7 | 6.8+0.3 7.1 | 15.8+0.3 16.1 | 14.8+0.3 15.1 | 14.1+0.3 14.4 | 24.6+0.8 25.4 | 21.8+0.8 22.6 | 24.4+0.8 25.2 | 21.5+0.8 22.3 |
| D.128 - Z38 | 9.4+0.5 9.9 | 6.8+0.5 7.3 | 15.8+0.5 16.3 | 14.8+0.5 15.3 | 14.1+0.5 14.6 | 24.6+0.8 25.4 | 21.8+1.2 23.0 | 24.4+0.7 25.1 | 21.5+1.2 22.7 |
| D.128 - Z48 | 9.4+1.0 10.4 | 6.8+1.0 7.8 | 15.8+1.0 16.8 | 14.8+1.0 15.8 | 14.1+1.0 15.1 | 24.6+1.8 26.4 | 21.8+2.4 24.2 | 24.4+1.8 26.2 | 21.5+2.4 23.9 |
| D.128 - D38 | 9.4+0.5 9.9 | 6.8+0.5 7.3 | 15.8+0.5 16.3 | 14.8+0.5 15.3 | 14.1+0.5 14.6 | 24.6+0.9 25.5 | 21.8+1.1 22.9 | 24.4+0.9 25.3 | 21.5+1.1 22.6 |
| D.148 - Z38 | 12.5+0.5 13.0 | 9.4+0.5 9.9 | 20.4+0.5 20.9 | 19.1+0.5 19.6 | 23.4+0.5 23.9 | 30.6+0.8 31.4 | 28.2+1.2 29.4 | 32.2+0.7 32.9 | 27.9+1.2 29.1 |
| D.148 - Z48 | 12.5+1.0 13.5 | 9.4+1.0 10.4 | 20.4+1.0 21.4 | 19.1+1.0 20.1 | 23.4+1.0 24.4 | 30.6+1.8 32.4 | 28.2+2.4 30.6 | 32.2+1.8 34.0 | 27.9+2.4 30.3 |
| D.148 - D38 | 12.5+0.5 13.0 | 9.4+0.5 9.9 | 20.4+0.5 20.9 | 19.1+0.5 19.6 | 23.4+0.5 23.9 | 30.6+0.9 31.5 | 28.2+1.1 29.3 | 32.2+0.9 33.1 | 27.9+1.1 29.0 |
| D.168 - Z48 | 19.0+1.0 20.0 | 16.0+1.0 17.0 | 34.1+1.0 35.1 | 31.2+1.0 32.2 | 33.8+1.0 34.8 | 53.0+1.8 54.8 | 43.7+2.4 46.1 | 54.4+1.8 56.2 | 42.2+2.4 44.6 |
| D.168 - Z68 | 19.0+1.7 20.7 | 16.0+1.7 17.7 | 34.1+1.7 35.8 | 31.2+1.7 32.9 | 33.8+1.7 35.5 | 53.0+3.0 56.0 | 43.7+4.1 47.8 | 54.4+3.0 57.4 | 42.2+4.1 46.3 |
| D.168 - D48 | 19.0+1.0 20.0 | 16.0+1.0 17.0 | 34.1+1.0 35.1 | 31.2+1.0 32.2 | 33.8+1.0 34.8 | 53.0+2.3 55.3 | 43.7+2.4 46.1 | 54.4+2.3 56.7 | 42.2+2.4 44.6 |
| D.188 - Z48 | 18.4+1.0 19.4 | 18.4+1.0 19.4 | 48.0+1.0 49.0 | 46.0+1.0 47.0 | 73.0+1.0 74.0 | 83.0+1.8 84.8 | 68.0+2.4 70.4 | 83.0+1.8 84.8 | 68.0+2.4 70.4 |
| D.188 - Z68 | 18.4+1.7 20.1 | 18.4+1.7 20.1 | 48.0+1.7 49.7 | 46.0+1.7 47.7 | 73.0+1.7 74.7 | 83.0+3.0 86.0 | 68.0+4.1 72.1 | 83.0+3.0 86.0 | 68.0+4.1 72.1 |
| D.188 - D48 | 18.4+1.0 19.4 | 18.4+1.0 19.4 | 48.0+1.0 49.0 | 46.0+1.0 47.0 | 73.0+1.0 74.0 | 83.0+2.3 85.3 | 68.0+2.4 70.4 | 83.0+2.3 85.3 | 68.0+2.4 70.4 |

Table 3.6.5.1: Oil quantities for Z.38 - Z.68, D.38 - D.188

3.6.5.2 Bevel-helical gear units

| Type | Mounting position | | | | | |
|--------------------|-------------------------|-------------------------|---------------------------|-------------------------|-------------------------|-------------------------|
| | B3-00 H-01 | B8-00 H-02 | B7-00 H-03 | B6-00 H-04 | V5-00 H-05 | V6-00 H-06 |
| K.38 - Z28 | 0.5+0.3 0.8 | 1.1+0.3 1.4 | 1.4+0.8 2.2 | 0.8+0.8 1.6 | 1.0+0.3 1.3 | 0.9+0.3 1.2 |
| K.48 - Z28 | 0.7+0.3 1.0 | 1.6+0.3 1.9 | 2.0+0.8 2.8 | 1.2+0.8 2.0 | 1.5+0.3 1.8 | 1.8+0.3 2.1 |
| K.68 - Z28 | 1.6+0.3 1.9 | 3.2+0.3 3.5 | 3.9+0.8 4.7 | 2.7+0.8 3.5 | 3.0+0.3 3.3 | 3.0+0.3 3.3 |
| K.68 - Z38 | 1.6+0.5 2.1 | 3.2+0.5 3.7 | 3.9+0.8 4.7 | 2.7+1.2 3.9 | 3.0+0.5 3.5 | 3.0+0.5 3.5 |
| K.68 - D38 | 1.6+0.5 2.1 | 3.2+0.5 3.7 | 3.9+0.9 4.8 | 2.7+1.1 3.8 | 3.0+0.5 3.5 | 3.0+0.5 3.5 |
| K.88 - Z28 | 2.6+0.3 2.9 | 5.7+0.3 6.0 | 7.4+0.8 8.2 | 5.0+0.8 5.8 | 4.9+0.3 5.2 | 5.2+0.3 5.5 |
| K.88 - Z38 | 2.6+0.5 3.1 | 5.7+0.5 6.2 | 7.4+0.8 8.2 | 5.0+1.2 6.2 | 4.9+0.5 5.4 | 5.2+0.5 5.7 |
| K.88 - D38 | 2.6+0.5 3.1 | 5.7+0.5 6.2 | 7.4+0.9 8.3 | 5.0+1.1 6.1 | 4.9+0.5 5.4 | 5.2+0.5 5.7 |
| K.108 - Z38 | 5.5+0.5 6.0 | 9.5+0.5 10.0 | 12.6+0.8 13.4 | 8.8+1.2 10.0 | 8.7+0.5 9.2 | 8.3+0.5 8.8 |
| K.108 - Z48 | 5.5+1.0 6.5 | 9.5+1.0 10.5 | 12.6+1.8 14.4 | 8.8+2.4 11.2 | 8.7+1.0 9.7 | 8.3+1.0 9.3 |
| K.108 - D38 | 5.5+0.5 6.0 | 9.5+0.5 10.0 | 12.6+0.9 13.5 | 8.8+1.1 9.9 | 8.7+0.5 9.2 | 8.3+0.5 8.8 |
| K.128 - Z38 | 8.3+0.5 8.8 | 19.6+0.5 20.1 | 24.4+0.8 25.2 | 15.8+1.2 17.0 | 16.9+0.5 17.4 | 16.1+0.5 16.6 |
| K.128 - Z48 | 8.3+1.0 9.3 | 19.6+1.0 20.6 | 24.4+1.8 26.2 | 15.8+2.4 18.2 | 16.9+1.0 17.9 | 16.1+1.0 17.1 |
| K.128 - D38 | 8.3+0.5 8.8 | 19.6+0.5 20.1 | 24.4+0.9 25.3 | 15.8+1.1 16.9 | 16.9+0.5 17.4 | 16.1+0.5 16.6 |
| K.148 - Z38 | 14.8+0.5 15.3 | 30.2+0.5 30.7 | 37.0+0.8 37.8 | 22.0+1.2 23.2 | 25.8+0.5 26.3 | 27.0+0.5 27.5 |
| K.148 - Z68 | 14.8+1.7 16.5 | 30.2+1.7 31.9 | 37.0+3.0 40.0 | 22.0+4.1 26.1 | 25.8+1.7 27.5 | 27.0+1.7 28.7 |
| K.148 - D38 | 14.8+0.5 15.3 | 30.2+0.5 30.7 | 37.0+0.9 37.9 | 22.0+1.1 23.1 | 25.8+0.5 26.3 | 27.0+0.5 27.5 |
| K.168 - Z48 | 21.6+1.0 22.6 | 45.6+1.0 46.6 | 60.5+1.8 62.3 | 34.2+2.4 36.6 | 40.2+1.0 41.2 | 38.5+1.0 39.5 |
| K.168 - Z68 | 21.6+1.7 23.3 | 45.6+1.7 47.3 | 60.5+3.0 63.5 | 34.2+4.1 38.3 | 40.2+1.7 41.9 | 38.5+1.7 40.2 |
| K.168 - D48 | 21.6+1.1 22.7 | 45.6+1.1 46.7 | 60.5+2.3 62.8 | 34.2+2.4 36.6 | 40.2+1.1 41.3 | 38.5+1.1 39.6 |
| K.188 - Z68 | 33.8+1.7 35.5 | 82.5+1.7 84.2 | 104.2+3 107.2 | 63.4+4.1 67.5 | 70.7+1.7 72.4 | 69.4+1.7 71.1 |
| K.188 - Z88 | 33.8+3.7 37.5 | 82.5+3.7 86.2 | 104.2+6.8 111 | 63.4+8.8 72.2 | 70.7+3.7 74.4 | 69.4+3.7 73.1 |
| K.188 - D68 | 33.8+1.6 35.4 | 82.5+1.6 84.1 | 104.2+3.9 108.1 | 63.4+4 67.4 | 70.7+1.6 72.3 | 69.4+1.6 71.0 |

Table 3.6.5.2–1: Oil quantities for K, KA, KAS, KAT Size 38 - 188

| Type | Mounting position | | | | | |
|--------------------|-------------------------|-------------------------|---------------------------|-------------------------|-------------------------|-------------------------|
| | B5-01 H-01 | B5-03 H-02 | B5-02 H-03 | B5-00 H-04 | V1-00 H-05 | V3-00 H-06 |
| K.38 - Z28 | 0.5+0.3 0.8 | 1.1+0.3 1.4 | 1.5+0.8 2.3 | 0.8+0.8 1.6 | 1.0+0.3 1.3 | 0.9+0.3 1.2 |
| K.48 - Z28 | 0.7+0.3 1.0 | 1.7+0.3 2.0 | 2.3+0.8 3.1 | 1.2+0.8 2.0 | 1.6+0.3 1.9 | 1.8+0.3 2.1 |
| K.68 - Z28 | 1.6+0.3 1.9 | 3.2+0.3 3.5 | 3.9+0.8 4.7 | 2.6+0.8 3.4 | 2.8+0.3 3.1 | 3.0+0.3 3.3 |
| K.68 - Z38 | 1.6+0.5 2.1 | 3.2+0.5 3.7 | 3.9+0.7 4.6 | 2.6+1.2 3.8 | 2.8+0.5 3.3 | 3.0+0.5 3.5 |
| K.68 - D38 | 1.6+0.5 2.1 | 3.2+0.5 3.7 | 3.9+0.9 4.8 | 2.6+1.1 3.7 | 2.8+0.5 3.3 | 3.0+0.5 3.5 |
| K.88 - Z28 | 2.6+0.3 2.9 | 5.8+0.3 6.1 | 7.7+0.8 8.5 | 5.0+0.8 5.8 | 5.1+0.3 5.4 | 5.0+0.3 5.3 |
| K.88 - Z38 | 2.6+0.5 3.1 | 5.8+0.5 6.3 | 7.7+0.7 8.4 | 5.0+1.2 6.2 | 5.1+0.5 5.6 | 5.0+0.5 5.5 |
| K.88 - D38 | 2.6+0.5 3.1 | 5.8+0.5 6.3 | 7.7+0.9 8.6 | 5.0+1.1 6.1 | 5.1+0.5 5.6 | 5.0+0.5 5.5 |
| K.108 - Z38 | 6.2+0.5 6.7 | 9.9+0.5 10.4 | 13.7+0.7 14.4 | 8.9+1.2 10.1 | 10.0+0.5 10.5 | 8.9+0.5 9.4 |
| K.108 - Z48 | 6.2+1.0 7.2 | 9.9+1.0 10.9 | 13.7+1.8 15.5 | 8.9+2.4 11.3 | 10.0+1.0 11.0 | 8.9+1.0 9.9 |
| K.108 - D38 | 6.2+0.5 6.7 | 9.9+0.5 10.4 | 13.7+0.9 14.6 | 8.9+1.1 10.0 | 10.0+0.5 10.5 | 8.9+0.5 9.4 |
| K.128 - Z38 | 8.7+0.5 9.2 | 19.6+0.5 20.1 | 25.0+0.7 25.7 | 14.8+1.2 16.0 | 17.5+0.5 18.0 | 16.6+0.5 17.1 |
| K.128 - Z48 | 8.7+1.0 9.7 | 19.6+1.0 20.6 | 25.0+1.8 26.8 | 14.8+2.4 17.2 | 17.5+1.0 18.5 | 16.6+1.0 17.6 |
| K.128 - D38 | 8.7+0.5 9.2 | 19.6+0.5 20.1 | 25.0+0.9 25.9 | 14.8+1.1 15.9 | 17.5+0.5 18.0 | 16.6+0.5 17.1 |
| K.148 - Z38 | 14.8+0.5 15.3 | 30.1+0.5 30.6 | 41.0+0.7 41.7 | 25.0+1.2 26.2 | 26.0+0.5 26.5 | 28.1+0.5 28.6 |
| K.148 - Z68 | 14.8+1.7 16.5 | 30.1+1.7 31.8 | 41.0+3.0 44.0 | 25.0+4.1 29.1 | 26.0+1.7 27.7 | 28.1+1.7 29.8 |
| K.148 - D38 | 14.8+0.5 15.3 | 30.1+0.5 30.6 | 41.0+0.9 41.9 | 25.0+1.1 26.1 | 26.0+0.5 26.5 | 28.1+0.5 28.6 |
| K.168 - Z48 | 21.7+1.0 22.7 | 46.3+1.0 47.3 | 62.6+1.8 64.4 | 34.8+2.4 37.2 | 41.1+1.0 42.1 | 39.4+1.0 40.4 |
| K.168 - Z68 | 21.7+1.7 23.4 | 46.3+1.7 48.0 | 62.6+3.0 65.6 | 34.8+4.1 38.9 | 41.1+1.7 42.8 | 39.4+1.7 41.1 |
| K.168 - D48 | 21.7+1.1 22.8 | 46.3+1.1 47.4 | 62.6+2.3 64.9 | 34.8+2.4 37.2 | 41.1+1.1 42.2 | 39.4+1.1 40.5 |
| K.188 - Z68 | 33.8+1.7 35.5 | 82.5+1.7 84.2 | 104.2+3 107.2 | 63.4+4.1 67.5 | 70.7+1.7 72.4 | 69.4+1.7 71.1 |
| K.188 - Z88 | 33.8+3.7 37.5 | 82.5+3.7 86.2 | 104.2+6.8 111 | 63.4+8.8 72.2 | 70.7+3.7 74.4 | 69.4+3.7 73.1 |
| K.188 - D68 | 33.8+1.6 35.4 | 82.5+1.6 84.1 | 104.2+3.9 108.1 | 63.4+4 67.4 | 70.7+1.6 72.3 | 69.4+1.6 71.0 |

Table 3.6.5.2–2: Oil quantities for KZ, KF, KAD, KAF, KAZ, KADS, KAFS, KAZS, KADT, KAFT, KAZT
Size 38 - 188

3.6.5.3 Parallel shaft helical gear units

| Type | Mounting position | | | | | |
|----------------------|-------------------------|-------------------------|-------------------------|-------------------------|-------------------------|-------------------------|
| | B5-01 H-01 | B5-03 H-02 | B5-02 H-03 | B5-00 H-04 | V1-00 H-05 | V3-00 H-06 |
| FD.38B - Z28 | 0.9+0.3 1.2 | 0.6+0.3 0.9 | 0.7+0.3 1.0 | 0.7+0.3 1.0 | 0.9+0.9 1.8 | 1.1+1.0 2.1 |
| FD.48B - Z28 | 2.0+0.3 2.3 | 0.9+0.3 1.2 | 1.3+0.3 1.6 | 1.3+0.3 1.6 | 1.8+0.9 2.7 | 2.0+1.0 3.0 |
| FD.48B - Z38 | 2.0+0.5 2.5 | 0.9+0.5 1.4 | 1.3+0.5 1.8 | 1.3+0.5 1.8 | 1.8+0.8 2.6 | 2.0+1.2 3.2 |
| FD.48B - D38 | 2.0+0.5 2.5 | 0.9+0.5 1.4 | 1.3+0.5 1.8 | 1.3+0.5 1.8 | 1.8+0.9 2.7 | 2.0+1.1 3.1 |
| FD.68B - Z28 | 3.3+0.3 3.6 | 2.3+0.3 2.6 | 2.4+0.3 2.7 | 2.3+0.3 2.6 | 3.2+0.9 4.1 | 3.8+1.0 4.8 |
| FD.68B - Z38 | 3.3+0.5 3.8 | 2.3+0.5 2.8 | 2.4+0.5 2.9 | 2.3+0.5 2.8 | 3.2+0.8 4.0 | 3.8+1.2 5.0 |
| FD.68B - D38 | 3.3+0.5 3.8 | 2.3+0.5 2.8 | 2.4+0.5 2.9 | 2.3+0.5 2.8 | 3.2+0.9 4.1 | 3.8+1.1 4.9 |
| FD.88B - Z28 | 6.3+0.3 6.6 | 5.0+0.3 5.3 | 4.7+0.3 5.0 | 4.7+0.3 5.0 | 6.8+0.9 7.7 | 6.7+1.0 7.7 |
| FD.88B - Z38 | 6.3+0.5 6.8 | 5.0+0.5 5.5 | 4.7+0.5 5.2 | 4.7+0.5 5.2 | 6.8+0.8 7.6 | 6.7+1.2 7.9 |
| FD.88B - D38 | 6.3+0.5 6.8 | 5.0+0.5 5.5 | 4.7+0.5 5.2 | 4.7+0.5 5.2 | 6.8+0.9 7.7 | 6.7+1.1 7.8 |
| FD.108B - Z38 | 10.6+0.5 11.1 | 9.1+0.5 9.6 | 8.2+0.5 8.7 | 8.2+0.5 8.7 | 11.1+0.8 11.9 | 13.0+1.2 14.2 |
| FD.108B - D38 | 10.6+0.5 11.1 | 9.1+0.5 9.6 | 8.2+0.5 8.7 | 8.2+0.5 8.7 | 11.1+0.9 12.0 | 13.0+1.1 14.1 |
| FD.128B - Z38 | 16.8+0.5 17.3 | 13.5+0.5 14.0 | 15.2+0.5 15.7 | 14.8+0.5 15.3 | 21.6+0.8 22.4 | 22.5+1.2 23.7 |
| FD.128B - Z48 | 16.8+1.0 17.8 | 13.5+1.0 14.5 | 15.2+1.0 16.2 | 14.8+1.0 15.8 | 21.6+1.8 23.4 | 22.5+2.4 24.9 |
| FD.128B - D38 | 16.8+0.5 17.3 | 13.5+0.5 14.0 | 15.2+0.5 15.7 | 14.8+0.5 15.3 | 21.6+0.9 22.5 | 22.5+1.1 23.6 |
| FD.148B - Z38 | 24.7+0.5 25.2 | 20.3+0.5 20.8 | 21.8+0.5 22.3 | 22.3+0.5 22.8 | 33.6+0.8 34.4 | 32.6+1.2 33.8 |
| FD.148B - Z48 | 24.7+1.0 25.7 | 20.3+1.0 21.3 | 21.8+1.0 22.8 | 22.3+1.0 23.3 | 33.6+1.8 35.4 | 32.6+2.4 35.0 |
| FD.148B - D38 | 24.7+0.5 25.2 | 20.3+0.5 20.8 | 21.8+0.5 22.3 | 22.3+0.5 22.8 | 33.6+0.9 34.5 | 32.6+1.1 33.7 |
| FD.168B - Z48 | 44.0+1.0 45.0 | 28.8+1.0 29.8 | 36.0+1.0 37.0 | 35.8+1.0 36.8 | 52.4+1.8 54.2 | 51.9+2.4 54.3 |
| FD.168B - Z68 | 44.0+1.7 45.7 | 28.8+1.7 30.5 | 36.0+1.7 37.7 | 35.8+1.7 37.5 | 52.4+3.0 55.4 | 51.9+4.1 56.0 |
| FD.168B - D48 | 44.0+1.0 45.0 | 28.8+1.0 29.8 | 36.0+1.0 37.0 | 35.8+1.0 36.8 | 52.4+2.3 54.7 | 51.9+2.4 54.3 |
| FD.188B - Z48 | 52.0+1.0 53.0 | 38.4+1.0 39.4 | 44.5+1.0 45.5 | 45.1+1.0 46.1 | 66.0+1.8 67.8 | 65.2+2.4 67.6 |
| FD.188B - Z68 | 52.0+1.7 53.7 | 38.4+1.7 40.1 | 44.5+1.7 46.2 | 45.1+1.7 46.8 | 66.0+3.0 69.0 | 65.2+4.1 69.3 |
| FD.188B - D48 | 52.0+1.0 53.0 | 38.4+1.0 39.4 | 44.5+1.0 45.5 | 45.1+1.0 46.1 | 66.0+2.3 68.3 | 65.2+2.4 67.6 |

Table 3.6.5.3: Oil quantities for F.38B - F.188B

3.6.5.4 Helical worm gear units

| Type | Mounting position | | | | | |
|-------------------|-------------------|----------------|----------------|----------------|----------------|----------------|
| | B3-00 H-01 | B8-00 H-02 | B7-00 H-03 | B6-00 H-04 | V5-00 H-05 | V6-00 H-06 |
| C.38 - Z28 | 0.5+0.3 0.8 | 1.2+0.3 1.5 | 1.3+0.8 2.1 | 1.2+0.8 2.0 | 1.2+0.3 1.5 | 1.2+0.3 1.5 |
| C.48 - Z28 | 0.7+0.3 1.0 | 1.6+0.3 1.9 | 1.7+0.8 2.5 | 1.6+0.8 2.4 | 1.3+0.3 1.6 | 1.3+0.3 1.6 |
| C.68 - Z28 | 1.5+0.3 1.8 | 3.3+0.3 3.6 | 4.1+0.8 4.9 | 3.3+0.8 4.1 | 2.8+0.3 3.1 | 2.9+0.3 3.2 |
| C.68 - Z38 | 1.5+0.5 2.0 | 3.3+0.5 3.8 | 4.1+0.8 4.9 | 3.3+1.2 4.5 | 2.8+0.5 3.3 | 2.9+0.5 3.4 |
| C.68 - D38 | 1.5+0.5 2.0 | 3.3+0.5 3.8 | 4.1+0.9 5.0 | 3.3+1.1 4.4 | 2.8+0.5 3.3 | 2.9+0.5 3.4 |
| C.88 - Z28 | 1.7+0.3 2.0 | 6.1+0.3 6.4 | 6.5+0.8 7.3 | 5.1+0.8 5.9 | 4.5+0.3 4.8 | 4.5+0.3 4.8 |
| C.88 - Z38 | 1.7+0.5 2.2 | 6.1+0.5 6.6 | 6.5+0.8 7.3 | 5.1+1.2 6.3 | 4.5+0.5 5.0 | 4.5+0.5 5.0 |
| C.88 - D38 | 1.7+0.5 2.2 | 6.1+0.5 6.6 | 6.5+0.9 7.4 | 5.1+1.1 6.2 | 4.5+0.5 5.0 | 4.5+0.5 5.0 |

Table 3.6.5.4–1: Oil quantities for C, CA, CAS, CAT Size 38 - 88

| Type | Mounting position | | | | | |
|-------------------|-------------------|----------------|----------------|----------------|----------------|----------------|
| | B5-01 H-01 | B5-03 H-02 | B5-02 H-03 | B5-00 H-04 | V1-00 H-05 | V3-00 H-06 |
| C.38 - Z28 | 0.4+0.3 0.7 | 1.2+0.3 1.5 | 1.3+0.8 2.1 | 1.1+0.8 1.9 | 1.0+0.3 1.3 | 1.0+0.3 1.3 |
| C.48 - Z28 | 0.5+0.3 0.8 | 1.7+0.3 2.0 | 1.8+0.8 2.6 | 1.6+0.8 2.4 | 1.3+0.3 1.6 | 1.3+0.3 1.6 |
| C.68 - Z28 | 1.5+0.3 1.8 | 3.6+0.3 3.9 | 4.2+0.8 5.0 | 3.3+0.8 4.1 | 3.1+0.3 3.4 | 3.2+0.3 3.5 |
| C.68 - Z38 | 1.5+0.5 2.0 | 3.6+0.5 4.1 | 4.2+0.8 5.0 | 3.3+1.2 4.5 | 3.1+0.5 3.6 | 3.2+0.5 3.7 |
| C.68 - D38 | 1.5+0.5 2.0 | 3.6+0.5 4.1 | 4.2+0.9 5.1 | 3.3+1.1 4.4 | 3.1+0.5 3.6 | 3.2+0.5 3.7 |
| C.88 - Z28 | 1.7+0.3 2.0 | 6.6+0.3 6.9 | 7.3+0.8 8.1 | 5.2+0.8 6.0 | 4.8+0.3 5.1 | 4.8+0.3 5.1 |
| C.88 - Z38 | 1.7+0.5 2.2 | 6.6+0.5 7.1 | 7.3+0.8 8.1 | 5.2+1.2 6.4 | 4.8+0.5 5.3 | 4.8+0.5 5.3 |
| C.88 - D38 | 1.7+0.5 2.2 | 6.6+0.5 7.1 | 7.3+0.9 8.2 | 5.2+1.1 6.3 | 4.8+0.5 5.3 | 4.8+0.5 5.3 |

Table 3.6.5.4–2: Oil quantities for CZ, CF, CAD, CAF, CAZ, CADS, CAFS, CAZS, CADT, CAFT, CAZT Size 38 - 88

4. Technical description

4.1 General description

The gear units are supplied with one, two or three transmission stages. The gear units are suitable for the different mounting positions, taking into consideration the oil level.

4.2 Housing

The gear unit housings of grey cast iron are designed for continuous operation.

4.3 Toothed components

The toothed components of the gear unit are hardened. In the case of helical-gear units the worm is hardened and ground and the gear manufactured from bronze.

4.4 Lubrication

The toothed components are adequately supplied with lubricant by dip lubrication.

4.5 Shaft bearing

All shafts are mounted in rolling bearings. The rolling bearings are lubricated by dip lubrication or oil spray lubrication. Bearings that are not supplied with lubricant are closed and grease-lubricated.

4.6 Shaft seals

Radial shaft sealing rings at the shaft outlets prevent lubricant from escaping from the housing and dirt from entering. Where (by contractual agreement) housings are subjected to high temperatures, shaft sealing rings of temperature-resistant material are used.

4.7 Cooling



Caution.
Dirt deposits impair cooling.

The gear units normally require no additional cooling. The generously dimensioned housing surface is sufficient for conducting away dissipated heat where there is free convection. If the difference between the temperature of the housing and the ambient temperature (max. +40 °C) exceeds 70 K, please contact the **FLENDER TÜBINGEN GMBH** customer service.

4.8 Couplings

As a rule, flexible couplings are provided for the input and output drive sides of the gear unit.

If rigid couplings or other input or output elements which generate additional radial and / or axial forces (e.g. gear wheels, belt pulleys) are to be used, this must be agreed by contract.



Caution.
Couplings with peripheral velocities on the outer diameter of up to 30 m/s must be statically balanced. Couplings with peripheral velocities over 30 m/s must be dynamically balanced.

The special operating instructions should be observed for operation of the couplings.

4.9 Backstop

For certain requirements, the gear units can be fitted with a mechanical backstop. It can be fitted either in the coupling housing or in the bevel-helical gear unit. It permits only the correct direction of rotation during the operation of the unit. This is marked by a corresponding direction arrow.



Caution.

Damage or destruction of the backstop through wrong direction of rotation.
Do not run motor against the backstop.
Observe information on the gear unit.

The backstop is fitted with centrifugally operated sprags. When the gear unit is running in the specified direction, the inner ring and the cage with the sprags also rotate while the outer ring remains stationary.

Where the backstop is used in the coupling housing, lifting of the sprags is ensured at speeds above 1 000 rpm. The backstop is wear-free.



Caution.

In the case of applications at speeds under 1 000 rpm or frequent starting and stopping operations (≥ 20 starts / stops an hour) the service life is limited.
Ensure that the backstop is replaced in good time.

If used in the bevel-helical gear unit, the backstop operates below the lift-off speed of the sprags in the oil. The oil must be changed at the same intervals as those of the gear unit.

4.10 Rating plates

The rating plates of the gear units or gear motors are normally of coated aluminium foil. They are covered with a special masking film which guarantees permanent resistance to UV radiation and media of all kinds (oils, greases, salt water, cleaning agents, etc.).

The adhesives and materials are selected to ensure extremely firm adhesion and permanent high legibility, even at the limits of the range of operating temperatures ($-40\text{ °C} \dots +155\text{ °C}$).

The edges of the rating plates are coated with a matching special paint, see section 4.11 "Paint coats".

In special cases, i.e. special specifications, riveted or bolted metal plates are used.

4.11 Paint coats

4.11.1 General

All paint finishes are sprayed on.



Drives in ATEX version.

Plastic surfaces exposed to friction in normal operation can become electrostatically charged.

With use in zone 21 and 22 (dusts) the thickness of the paint finish must not exceed 200 µm.



Note.

Information on repaintability is not a guarantee of the quality of the paint material supplied by your supplier.

Only the paint manufacturer is liable for the quality and compatibility.

4.11.2 Painted version

| Paint system | Plastic | 2K-PUR | 2K-epoxide |
|------------------------------------|---|--|--|
| Colours | RAL 1007, 1012, 1023, 2000, 2004, 3000, 5007, 5009, 5010, 5012, 5015, 6011, 7001, 7011, 7030, 7032, 7035, 9005, 9006, black-mat | RAL 1003, 1018, 2004, 5002, 5015, 6011, 7000, 7031, 9010, 9011, 9016 | RAL 5015, 6018, 7031, 7035 |
| Typical area of application | Standard-1-layer paint finish for interior areas | Standard 2-layer paint finish, especially for outside installation or higher corrosion protection requirements | high-quality paint finish in the outside area or where exposed to dilute acid and alkaline solution ($\leq 5\%$) |
| Repaintability | after prior rubbing down with: Plastic or synthetic resin paint | after prior rubbing down with: 2K-PUR paint, 2K-epoxide paint | after prior rubbing down with: 2K-PUR paint, 2K-epoxide paint, 2K-AC paint |
| Chem. phys. resistance | good resistance to: cleaning agent, oil and petrol; resistant to: exposure to dilute acid and alkaline solution for a short time ($\leq 3\%$); not solvent-resistant; not steam-resistant | very good resistance to: oil, grease, petrol, water, seawater and cleaning agent; good resistance to: weather action and dilute acid and alkaline solution ($\leq 3\%$); good mechanical resistance to: abrasion | excellent resistance to: weak acid and alkaline solution ($\leq 5\%$), oil, grease, petrol, cooling emulsion, salt, solvent; tough and scratchproof paint film |
| Temperature resistance | -40 °C ... +100 °C temporarily up to 140 °C | -40 °C ... +150 °C | -40 °C ... +150 °C |
| Remark | Standard paint finish with very good adhesive property, not suitable for: storage or installation outside | Standard paint finish for cooling tower and agitator drives or, if requested, resistance to sea water below deck, etc. | 2K-epoxide paint becomes chalky when installed outside (without effect on quality), high gloss with good mechanical resistance |

Table 4.11.2: Painted version

4.11.3 Primed version

| Paint system | primed | unpainted |
|-----------------------------|---|--|
| Standard colour | RAL 7032 | - |
| Typical area of application | for repainting*): adhesion promoter for all common paint systems, temporary corrosion prevention | for repainting*): temporary corrosion prevention |
| Repaintability | very good with: plastic paint, synthetic resin paint, 2K-PUR paint, 2K-epoxide paint, SH paint, 2K-AC paint | very good with: Plastic paint, synthetic resin paint, oil paint, bitumen paint, 2K-PUR paint, 2K-epoxide paint |
| Chem. phys. resistance | good resistance to: cleaning agent, good salt-spray resistance; resistant to: oil and petrol | - |
| Temperature resistance | -40 °C ... +150 °C | (-40 °C ... +150 °C) |
| Remark | Adhesion promoter with very good adhesive property and good corrosion prevention | GCI parts, dip-primed, steel parts primed or galvanised, aluminium and plastic parts untreated |

Table 4.11.3: Primed version

*) On drive versions which are primed or unpainted the rating plate and the masking film are covered with a paint-protective film, see section 4.10 "Rating plates". It enables repainting without further preparation, e.g. masking with adhesive tape.

Peel off paint-protective film

The paint coat must have fully hardened before the paint-protective film is peeled off (be at least "touch-proof").

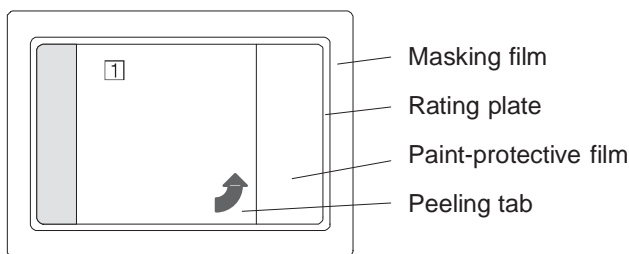

Figure 4.11.3: Peel off paint-protective film

① Company Logo

- 1) Pull peeling tab up.
- 2) Carefully peel the paint-protective film off diagonally from one corner (not parallel to the plate).
- 3) If necessary, blow paint fragments away or wipe them off with a clean cloth.

5. Incoming goods, Handling and Storage

5.1 Incoming goods



Note.

Inspect the delivery immediately after arrival for completeness and any transport damage.

Notify the freight company of any damage caused during transport immediately, as otherwise it is not possible to have damage rectified free of charge.



Caution.

Ensure that damaged drives are not put into operation.

The drive unit is delivered in the fully assembled condition. Additional items are delivered separately packaged.

The products supplied are listed in the despatch papers.

5.2 Handling

Different forms of packaging may be used, depending on the size of the drive and method of transport. Unless otherwise agreed, the packaging complies with the **HPE Packaging Guidelines** (Bundesverband Holzpackmittel Paletten Exportverpackungen e.V.).

Note the symbols applied to the packing. These have the following meanings:



This way up



Fragile



Keep dry



Keep cool



Centre of gravity



Use no hand hook



Attach here

Figure 5.2–1: Symbols on packaging

Fasten drive for suspended transport



Danger.

Adhere to the maximum load in direction F of the transport eyes and eye bolt axis, see figure and table 5.2–2 bzw. 5.2–3 “Max. load in kg from drive to be attached”.

Use eye bolt on motor only for transporting the unmounted or demounted motor or as auxiliary support for the drive, e.g. to achieve a horizontal mounting position.

If necessary, use additional, suitable carrying means for transport or on installation. When attaching by a number of chains and ropes just two strands must be sufficient to bear the entire load. Secure carrying means against slipping.

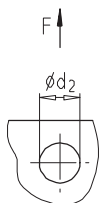

| | K.38 | K.48 | K.68 | K.88 | K.108 | K.128 | K.148 | K.168 | K.188 |
|------------|------|------|------|------|-------|-------|-------|-------|-------|
| d_2 [mm] | 22 | 22 | 26 | 30 | 35 | 40 | 44 | 55 | 55 |
| m [kg] | 200 | 250 | 350 | 600 | 750 | 800 | 1300 | 1800 | 2300 |

Figure and Table 5.2–2: Max. load in kg from drive to be attached, with pull \uparrow in direction F.

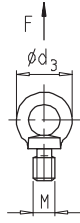

| d_3 [mm] | 36 | 45 | 54 | 63 | 72 | 90 | 108 |
|---------------|------------|-------------|-------------|-------------|-------------|-------------|-------------|
| M | M 8 | M 10 | M 12 | M 16 | M 20 | M 24 | M 30 |
| m [kg] | 140 | 230 | 340 | 700 | 1200 | 1800 | 3600 |

Figure and Table 5.2–3: Max. load in kg from drive to be attached, with pull \uparrow in direction F of the bolt axis.



Caution.

Do not use the front threads at the shaft ends to attach eye bolts for transport.



Caution.

The use of force causes damage to the drive unit.

Transport drive carefully. Avoid knocks.

Remove any transport fixtures fitted before putting into operation and keep them safe or render them ineffective. Use them again for further transport or render them ineffective again.

- 1) Mount the drive on the transport device by the heaviest permissible weight to be attached. This will normally be on the main gear unit.
- 2) Check that the eye bolt is firmly seated.
- 3) Drive is slung for transport.

5.3 Storage

The gear unit must be stored in its position of use on a horizontal wooden support in a dry place not subject to high temperature fluctuations and covered over. The storage place must be free from vibration and shaking.



Danger.

Do not stack drive units one on top of another.



Caution.

Mechanical damage (scratches), chemical damage (acids, alkalis) and thermal damage (sparks, welding beads, heat) cause corrosion which may cause failure of the external protective coating.

Ensure that the paint is not damaged.

The drive units are provided with an interior preservative agent; the free shaft ends and flanges are painted for protection.



Note.

The guarantee period for the standard preservative lasts 6 months and, unless otherwise agreed, begins at the date of delivery of the gear unit.

In the case of longer periods of storage (> 6 months) special arrangements must be made for preservation. Contact the **FLENDER TÜBINGEN GMBH** customer service.

6. Installation

6.1 General information on installation



Danger.

When working with solvents, ensure adequate ventilation. Do not inhale vapours. Do not smoke!



Caution.

Overheating of the drives through exposure to direct sunlight. Provide suitable safety equipment, such as covers and roofs.



Caution.

Irreparable damage to toothed components and bearings from fusing. Do not carry out any welding work on the drive. The drives must not be used as an earthing point for welding operations.



Note.

Use headless bolts of strength class 8.8 or higher to fasten the drives.



Drives in ATEX version.

Affect on bearings of stray electric currents from electrical equipment. When mounting or connecting the gear unit to the machine care must be taken that potential is equalised.

Exercise particular care when assembling and installing. The manufacturer cannot be held liable for damage caused by incorrect assembly and installation.

Ensure that there is sufficient space around the drive for assembly, maintenance and repair.

On drives with a fan leave sufficient free space for the entry of air.

Provide sufficient lifting gear at the start of assembly and fitting work.

Use all the fastening means which have been assigned to the relevant assembly option.

6.2 Fastening in the case of reversing operation or high shock loads

In the case of reversing operation or high shock loads provide additional suitable positive fastenings such as cylindrical taper pins or spring pins.



Caution.

Do not use spring washers, serrated lock washers, spring or toothed lock washers, cup washers or conical spring washers as a substitute for the above mentioned positive fastenings.

Do not subject the gear unit housing to excessive stress when tightening the fastening bolts.

Cap screws cannot be used in some cases, as there is insufficient space available for inserting them. In case of doubt please contact the **FLENDER TÜBINGEN GMBH** customer service, quoting the type of gear unit.

6.3 Drives with foot mounting

6.3.1 Foundation

The foundation must be level and free from dirt.



Note.

The levelness of the gear unit support must not exceed the following values:
for gear units up to size 88 ≤ 0.1 mm
for gear units from size 108 ≤ 0.2 mm.

The foundation should be designed in such a way that no resonance vibrations are created and that no vibrations are transmitted from adjacent foundations.

Steel structures on which the unit is to be mounted must be rigid. They must be designed according to the weight and torque, taking into account the forces acting on the gear unit.

When fastening the gear unit to concrete foundations by means of foundation blocks, suitable recesses should be made in the foundation.

Align and grout the slide rails into the foundation.

6.3.2 Installing gear units with foot mounting

Use stud bolts or headless bolts of strength class 8.8 or higher for the foot mounting.

6.4 Drive units in foot or flange version

The drive must be fastened for force and torque transmission only to either the flange or the foot mounting in accordance with section 6.3 "Drives with foot mounting" to prevent overstress on the gear unit housings.

The second mounting option (foot or flange) is usually intended for add-on elements, e.g. safety covers with an intrinsic weight of up to 30 % of the weight of the drive.



Caution.

Do not subject gear housings to overstress from add-on elements.
Add-on elements must not transmit forces, torques and vibration to the drives.

6.5 Drive units with C-type housing flange

In the case of sizes 108 - 188 the customer's interface can be pinned on the C-type housing flange. The drive flanges are designed to enable the permissible torques and radial forces to be reliably transmitted by the bolt connections.

For additional fastening, e.g. in the case of reversing operation or high shock loads, the drilled pin holes can be used.

The gear unit can also be drilled and pinned together with the machine. For this the specified dimensions must be adhered to.



Caution.
Observe maximum drilling depth (A-A).

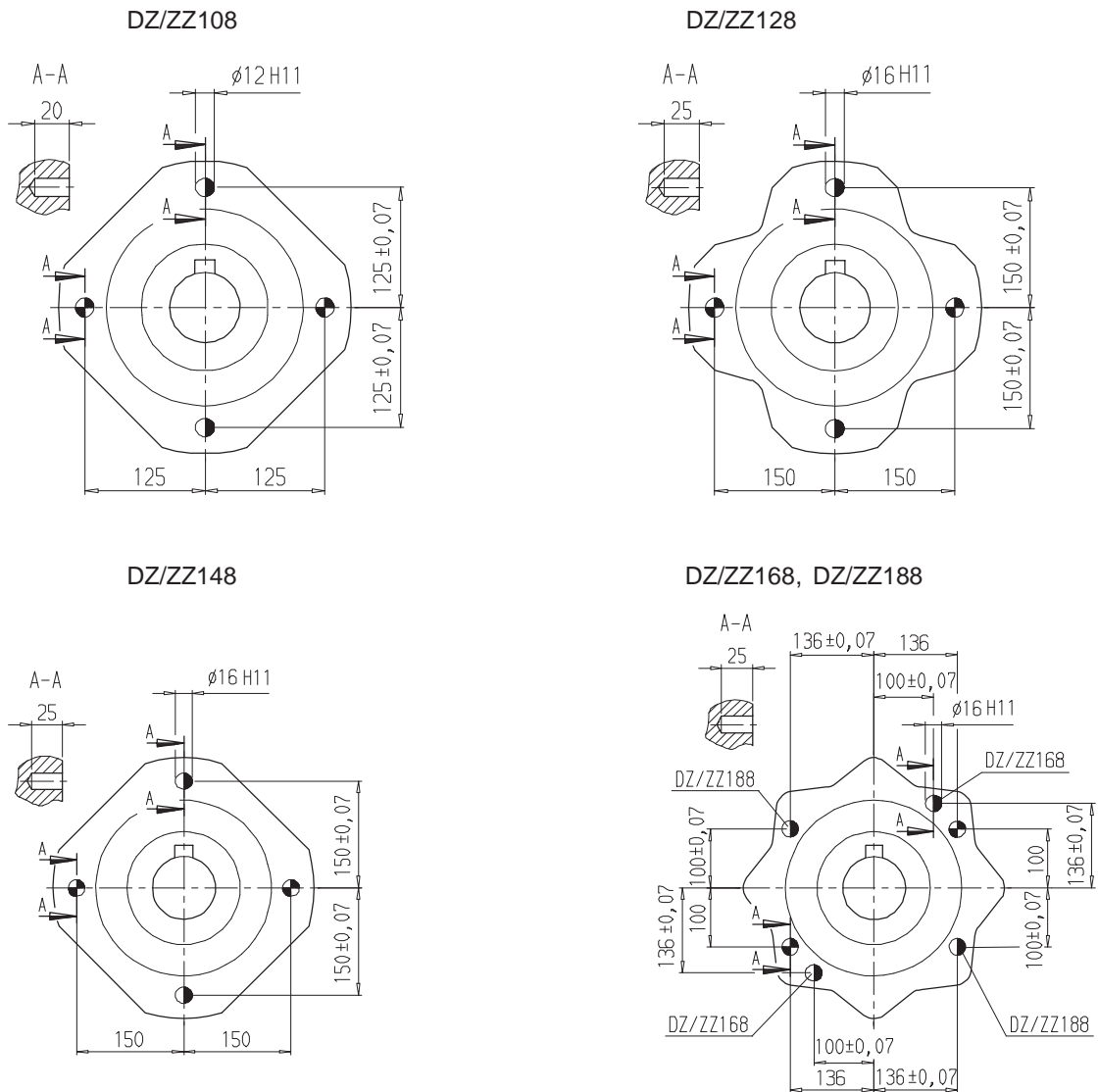
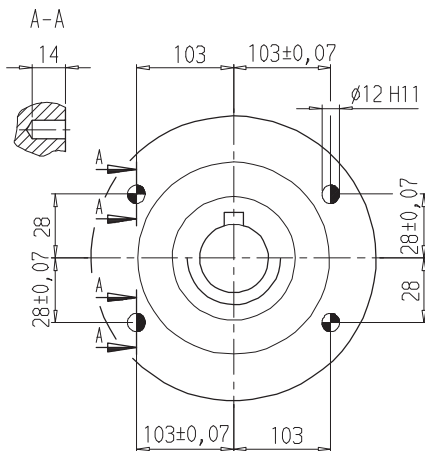
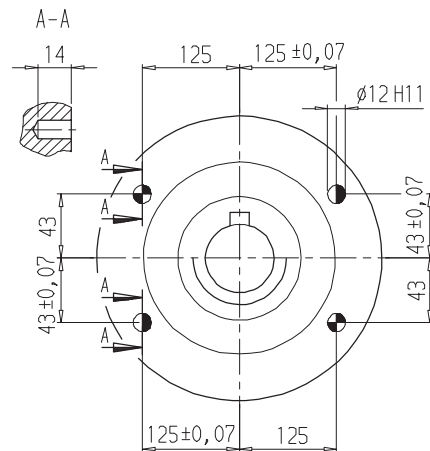

Figure 6.5–1: C-type housing flange helical gear units

K.Z.108, F.Z.108B



K.Z.128, F.Z.128B



K.Z.148, F.Z.148B

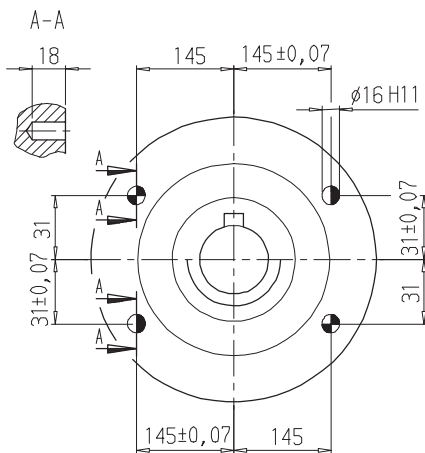

K.Z.168, K.Z.188, F.Z.168B, F.Z.188B

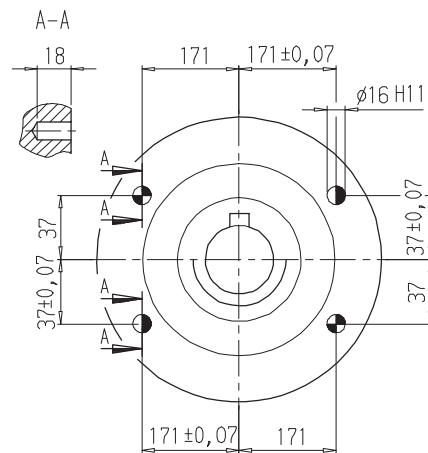

Figure 6.5–2: C-type housing flange bevel helical gear units and parallel shaft helical gear units

- Spring pins, heavy-duty design, to DIN 1481: Use pin holes provided in the housing flange.
- ⊕ Cylindrical grooved pins with chamfer to DIN EN 28740/ISO 8740: Drill connecting component together with housing.

6.6 Installation of input drive and output drive elements on gear unit shafts

Use a fitting device to fit the drive or output elements.

Located in the shaft end faces are centring holes to DIN 332 which can be used for this.

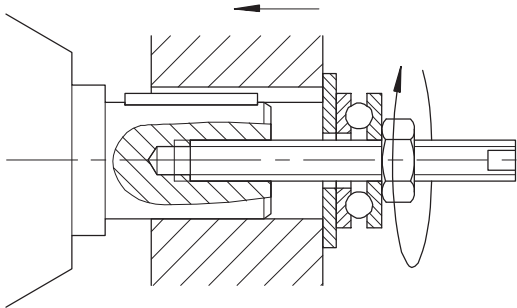

Example of a fitting device for fitting couplings or hubs on the ends of gear unit or motor shafts. If necessary, the axial thrust bearing on the fitting device can be dispensed with.

Figure 6.6–1: Fitting device



Note.

Deburr the parts of elements to be fitted in the area of the hole or keyways.
Recommendation: 0.2 x 45°

Mount in- or output elements



Caution.

Damage to shaft sealing ring through solvent or benzine.
Protect against contact at all time.

- 1) Using petrol ether or solvent, remove the corrosion-preventive paint coat on the shaft ends and flanges or remove any protective skin provided.



Caution.

Damage to bearings, housing, shaft and locking rings.
Do not use a hammer to force the drive and output elements to be mounted onto the shaft.

- 2) Fit the drive and output elements onto the shafts and, if necessary, secure them.

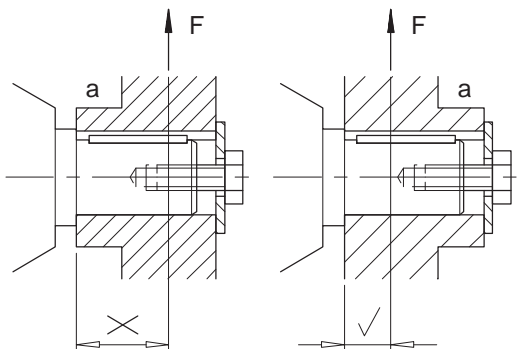

Correct mounting arrangement of running wheel, gear or chain wheel, belt pulley, etc., to keep the shaft and bearing load exerted by transverse forces as low as possible.

Figure 6.6–2: Mounting arrangement

a Hub

✗ wrong

✓ right

Where couplings are to be fitted in a heated condition, please observe the specific operating instructions for the coupling.

6.7 Steel safety cover for hollow shaft and shrink disc



Drives in ATEX version.
Sparks may be caused by a damaged safety cover.
Replace damaged safety cover immediately.

The steel safety cover is delivered ready-fitted to the gear unit flange. The safety cover must be demounted to fit the output shaft.

Mounting the protective cover

- 1) Undo screws part 1 and remove protective cover part 2.
- 2) Using a suitable cleaning agent, clean the support surface of the safety cover, part 2, on the gear unit.
- 3) Ensure that the O-ring, part 3, is correctly seated.
- 4) Coat the supporting surface of the safety cover, part 2, with a suitable sealing agent.
- 5) Fasten protective cover part 2 by screws.

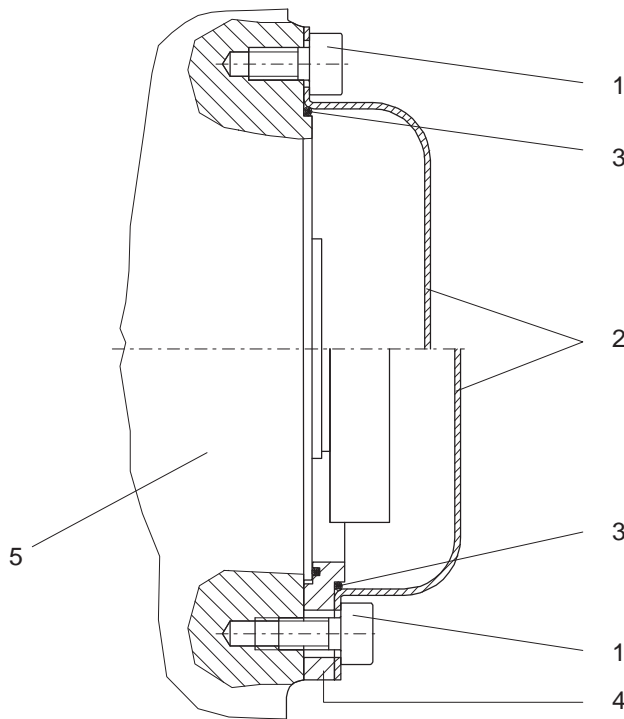

Figure 6.7: Steel safety cover

- | | | |
|--------------------|----------------|---------------------|
| 1 Bolt | 3 O-ring | 5 Gear unit housing |
| 2 Protective cover | 4 Adaptor ring | |

The adaptor ring, part 4, is provided only on foot-mounted versions of bevel-helical gear units sizes 68, 108, 128, 148 and 168.

6.8 Cast iron end cover for hollow shaft

The cast iron end cover is delivered ready-fitted on the gear unit flange. The end cover must be demounted to fit the output shaft.

Assembly of end cover

- 1) Undo screws part 1 and remove end cover part 2.
- 2) Using a suitable cleaning agent, clean the support surface of the end cover, part 2, on the gear unit.
- 3) Coat the supporting surface of the end cover, part 2, with a suitable sealing agent.
- 4) Fasten end cover part 2 by screws.

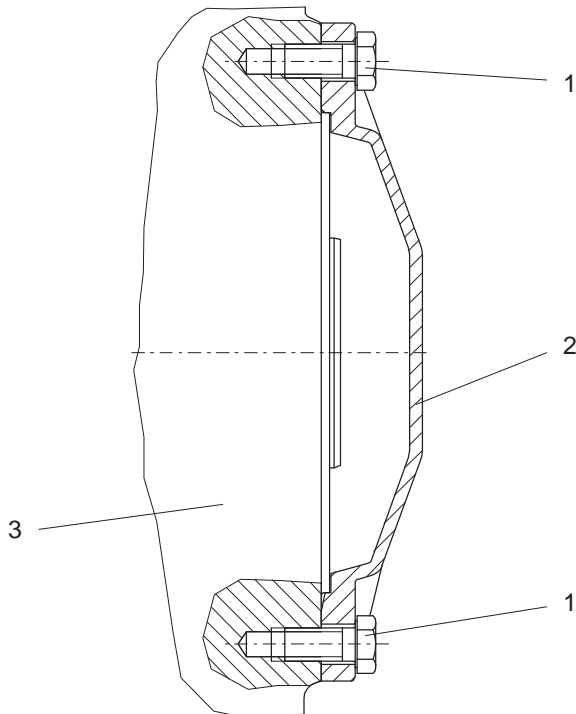

Figure 6.8: End cover made from cast iron

1 Bolt

2 End cover

3 Gear unit housing

**6.9 Shaft-mounting gear unit with hollow shaft and parallel key,
hollow shaft and splines,
hollow shaft and shrink disk**

6.9.1 Mounting the hollow shaft



Caution.

Damage to shaft sealing ring through solvent or benzine.
Protect against contact at all time.

- 1) Using petrol or a solvent, remove the corrosion-preventive paint coat from the shaft ends and flanges.
- 2) Check the seats or edges of the hollow and machine shaft for damage. In case of damage contact the **FLENDER TÜBINGEN GMBH** customer service.



Note.

Coat with the mounting paste which comes with the delivery or any suitable lubricant, e.g. Calypsol type H 443 HD88 grease, to prevent frictional corrosion of the contact surfaces.



Caution in the case of shrink disks.

Lubricants in the area of the shrink disk seat impair torque transmission.
Keep bore in hollow shaft and machine shaft completely grease-free.
Do not use impure solvents and cleaning cloths.

- 3) Fit the drive with the aid of nut and threaded spindle. The counterforce is provided by the hollow shaft.



Caution.

The hollow shaft must be precisely aligned with the machine shaft to avoid misalignment.

Failure of the bearings from overload in the case of flange-mounted drive.

Do not overstress hollow shaft axially and radially.

- 4) Secure the hollow shaft axially on the machine shaft with e.g. a locking ring, washer or set screw at a tightening torque T_A acc. to table 6.9.1 "Tightening torque T_A set screw".

| Size | 38 | 48 | 68 | 88 | 108 | 128 | 148 | 168 | 188 |
|------------|----|----|----|----|-----|-----|-----|-----|-----|
| T_A [Nm] | 16 | 28 | 69 | 69 | 138 | 138 | 138 | 237 | 237 |

Table 6.9.1: Tightening torque T_A set screw



Note for shrink disks.

The hollow shaft is axially secured on the machine shaft by means of a shrink disk connection.

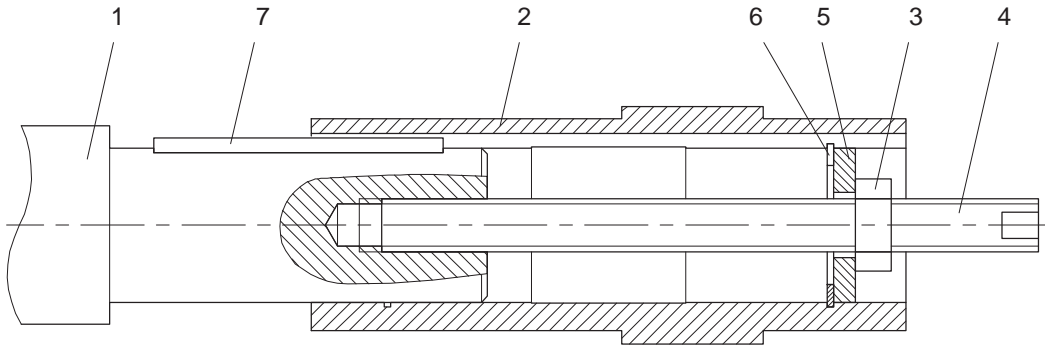

Figure 6.9.1–1: Mounting hollow shaft and parallel key

Part 3 - Part 4 are not included in scope of delivery.

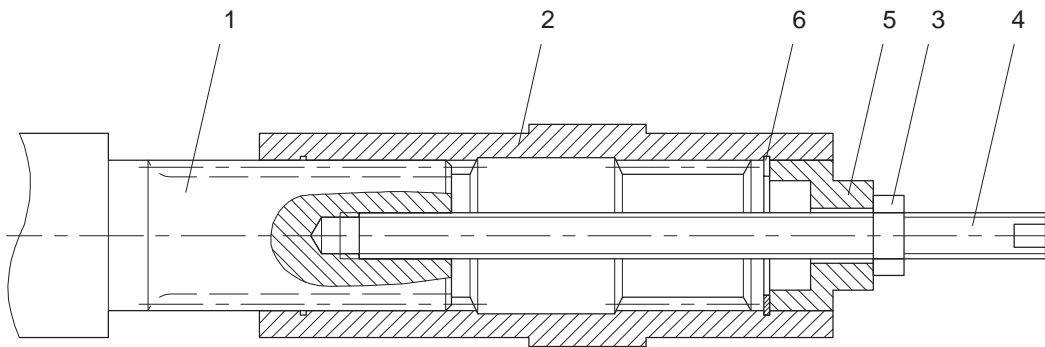

Figure 6.9.1–2: Mounting hollow shaft and splines

Part 3 - Part 4 are not included in scope of delivery.

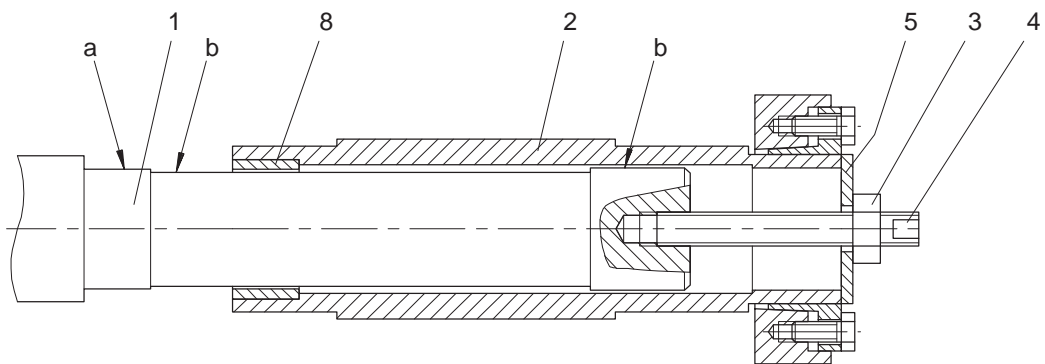

Figure 6.9.1–3: Mounting hollow shaft and shrink disk

a greased

b absolutely free of grease

Part 3 - Part 5 are not included in scope of delivery.

- | | | |
|-----------------|--------------------|----------------|
| 1 Machine shaft | 4 Threaded spindle | 7 Parallel key |
| 2 Hollow shaft | 5 Washer | 8 Bronze bush |
| 3 Hexagon nut | 6 Locking ring | |



Note.

Coat with a suitable lubricant, e.g. Calypsol type H 443 HD88 grease, to prevent frictional corrosion of the contact surfaces of the customer's machine shaft in the vicinity of the bronze bush.

Instead of the nut and threaded spindle shown in the diagram, other types of equipment such as hydraulic lifting equipment may be used.

6.9.2 Remove hollow shaft and parallel key



Caution.

Before driving out the machine shaft fasten a suitably dimensioned means of absorbing load to the drive.

Slightly pretension the drive element so that the drive does not drop into the drive element when the insert-shaft is released.

If frictional corrosion has occurred on the seat surfaces, use rust solvent to enable the gear unit to be pulled off. Allow the rust solvent to work in sufficiently.

- 1) Remove the axial fastening of the hollow shaft.



Caution.

It is essential to prevent misalignment when removing the gear unit.

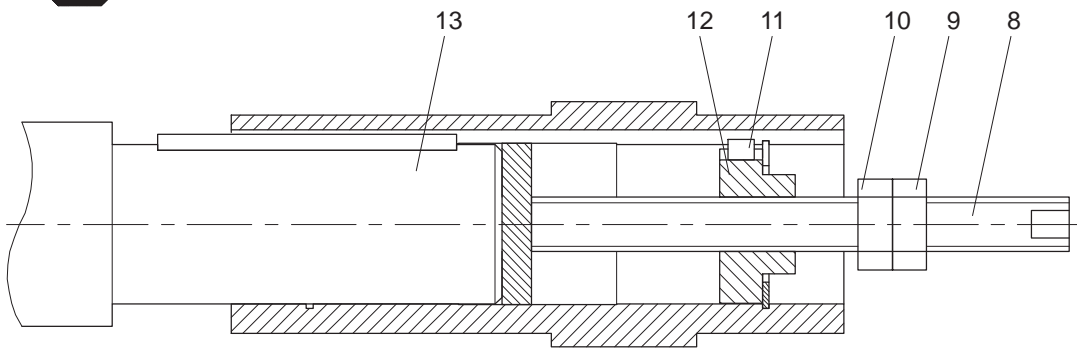

Figure 6.9.2: Remove hollow shaft and parallel key

| | | |
|--------------------|-----------------|-------------------|
| 8 Threaded spindle | 10 Hexagon nut | 12 Threaded block |
| 9 Hexagon nut | 11 Parallel key | 13 Washer |

Part 8 - Part 13 are not included in scope of delivery.

Suggested design for threaded piece and disc see figure 6.9.3 and table 6.9.3.

- 2) Drive out the machine shaft with the aid of the disk, part 13, threaded block, part 12, parallel key, part 11, and threaded spindle, parts 8 - 10.
- 3) When the rust solvent has sufficiently worked in, pull off the gear unit, using the device, see figure 6.9.2 "Remove hollow shaft and parallel key" .

6.9.3 Suggested design for threaded piece and disc

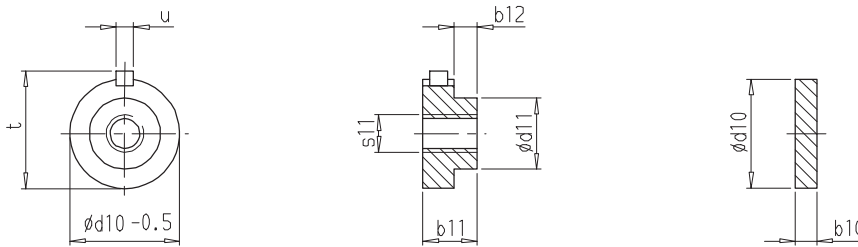

Figure 6.9.3: Suggested design for threaded piece and disc

| Size | b10 [mm] | b11 [mm] | b12 [mm] | d10 [mm] | d11 [mm] | s11 | t _{max} [mm] | u [mm] |
|------|-------------|-------------|-------------|-------------|-------------|---------|--------------------------|-----------|
| 38 | 6 | 15 | 10 | 29.9 | 20 | M10x1.5 | 33 | 8 |
| 48 | 6 | 15 | 5 | 34.9 | 24 | M12x1.5 | 43 | 10 |
| | | | | 39.9 | 28 | | | 12 |
| 68 | 7 | 20 | 7 | 39.9 | 28 | M16x1.5 | 48.5 | 12 |
| | | | | 44.9 | 33 | | | 14 |
| 88 | 7 | 20 | 10 | 49.9 | 36 | M16x1.5 | 64 | 14 |
| | | | | 59.9 | 45 | | | 18 |
| 108 | 10 | 24 | 10 | 59.9 | 45 | M20x1.5 | 74.5 | 18 |
| | | | | 69.9 | 54 | | | 20 |
| 128 | 10 | 24 | 5 | 69.9 | 54 | M20x1.5 | 85 | 20 |
| | | | | 79.9 | 62 | | | 22 |
| 148 | 10 | 24 | 7 | 79.9 | 62 | M20x1.5 | 95 | 22 |
| | | | | 89.9 | 72 | | | 25 |
| 168 | 10 | 30 | 8 | 99.9 | 80 | M24x1.5 | 106 | 28 |
| | | | | 109.9 | 90 | | 116 | |
| 188 | 10 | 30 | 11 | 119.9 | 95 | M24x1.5 | 127 | 32 |

Table 6.9.3: Suggested design for threaded piece and disc

6.10 Shrink disc

6.10.1 Mounting the shrink disc

The shrink disc is delivered ready for installation.



Caution.
Do not dismantle shrink disc before initial fitting.



Caution.
Lubricants in the area of the shrink disc seat impair torque transmission.
Keep bore in hollow shaft and machine shaft completely grease-free.
Do not use impure solvents and cleaning cloths.



Caution.
Plastic deformation of the hollow shaft when tightening the tensioning bolts before fitting the machine shaft.
First fit machine shaft. Then tighten tensioning bolts.

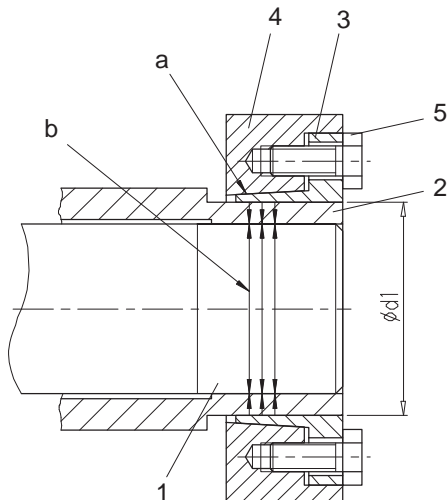

Figure 6.10.1–1: Shrink disc

- | | | | | | |
|---|---------------|---|---------------------------|---|-----------------|
| a | greased | b | absolutely free of grease | | |
| 1 | Machine shaft | 3 | Inner ring | 5 | Tensioning bolt |
| 2 | Hollow shaft | 4 | Outer ring | | |



Caution.
The end face of the hollow shaft, part 2, must be flush with the inner ring, part 3, of the shrink disc.



Caution.
Avoid overloading the individual bolts.
Do not exceed the maximum torque acc. to table 6.10.1 “Tightening torque T_A clamping screw” at $\mu = 0,1$.
Of prior importance is the alignment of the end faces. If this alignment is not achieved when tensioning, the tolerance of the stub shaft must be checked.

| Clamping screw thread | d1 | Tightening torque T _A strength class 10.9 | Tightening torque T _A strength class 12.9 |
|-----------------------|-----------|---|---|
| | [mm] | [Nm] | [Nm] |
| M 6 | 12 - 30 | 12 | - |
| M 8 | 36 - 68 | 29 | 35 |
| M 10 | 75 - 100 | 58 | 70 |
| M 12 | 105 - 125 | 100 | 121 |
| M 14 | 135 - 155 | 160 | 193 |
| M 16 | 160 - 200 | 240 | 295 |
| M 20 | 220 - 280 | 470 | 570 |

Table 6.10.1: Tightening torque T_A clamping screw

- 1) The clamping screws, part 5, must be tightened one after the other, working round several times, until the front faces of the outer and inner ring are flush..

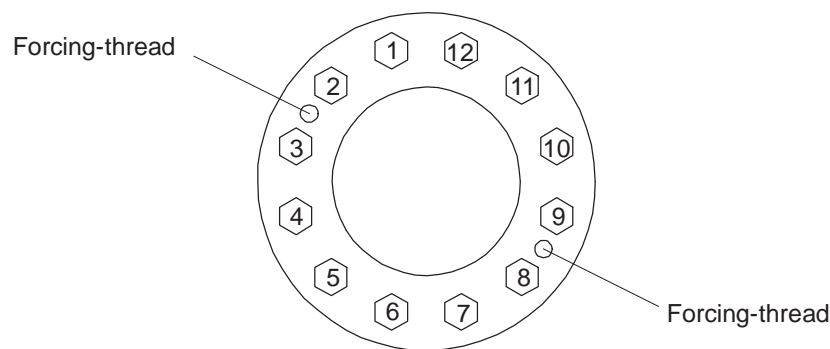

Figure 6.10.1–2: Sequence for tightening the clamping screws

- 2) In this way you can check for the optimum tightening condition.
- 3) If necessary, grease the outside surfaces of the hollow shaft in the area of the shrink disc seat.
- 4) Fit the safety cover delivered with the unit, see section 6.7 “Steel safety cover for hollow shaft and shrink disc”.

6.10.2 Pulling off the shrink disc

If the outer ring does not release from the inner ring, several clamping screws can be removed and then screwed into adjacent forcing threads.

The rings can then be released without difficulty.

- 1) Loosen the clamping screw one after the other, working round several times.
- 2) Pull the shrink disc from the hollow shaft.

6.10.3 Cleaning and greasing the shrink disc

Loosened shrink discs need not be dismantled and re-greased before being re-tensioned.

Dismantle and clean the shrink disc.

Before reassembly grease only the inner sliding surfaces of the shrink disc.

Use for this a solid lubricant with a friction coefficient of $\mu = 0.04$ in accordance with table 6.10.3 “Lubricants for shrink disc cleaning”.

| Lubricant | Commercial form | Manufacturer |
|------------------------------------|-----------------|--------------------|
| Molykote 321 R (lubricating paint) | Spray | DOW Corning |
| Molykote Spray (Powder spray) | | |
| Molykote G Rapid | Spray or Paste | Klüber Lubrication |
| Molykombin UMFT 1 | Spray | |
| Unimily P 5 | Powder | |
| Aemasol MO 19 P | Spray or Paste | A. C. Matthes |

Table 6.10.3: Lubricants for shrink disc cleaning

6.11 Attachment of standard motors

6.11.1 Fit standard motor on coupling housing with torsionally flexible coupling

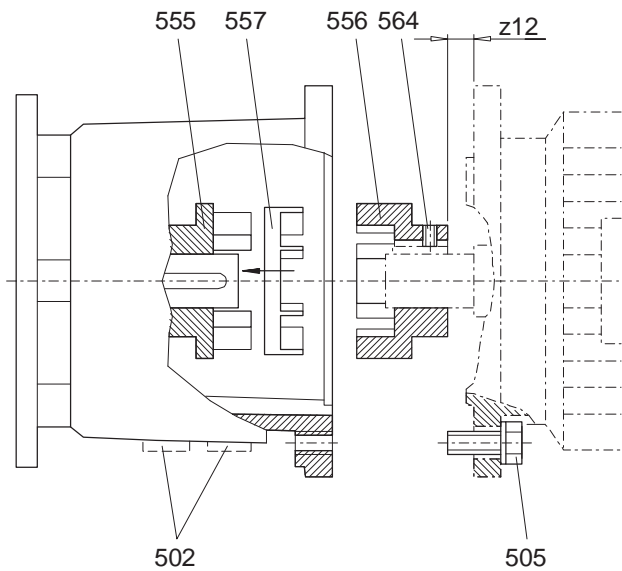

Figure 6.11.1: Coupling housing with torsionally flexible coupling

| | | |
|------------------------|-------------------|----------------------|
| 502 Plug | 555 Coupling half | 557 flexible element |
| 505 Hexagon head screw | 556 Coupling half | 564 Set screw |

- 1) Fit the coupling half, part 556, onto the end of the motor shaft in accordance with section 6.6 "Installation of input drive and output drive elements on gear unit shafts".
- 2) Adhere to the spacing dimension z12 acc. to table 6.11.1–3 "Distance dimension z12" ein.

| IEC B5 | 80 | 90 | 100 | 112 | 132 | 160 | 180 | 200 | 225 | 250 | 315 |
|----------|----|----|-----|-----|-----|-----|-----|-----|-----|-----|-----|
| z12 [mm] | 15 | 26 | 30 | 30 | 45 | 66 | 59 | 60 | 90 | 75 | 33 |

| NEMA TC | 56C | 143TC / 145TC | 182TC / 184TC | 213TC / 215TC | 254TC / 256TC | 284TC / 286TC | 324TC / 326TC | 364TC / 365TC |
|----------|------|---------------|---------------|---------------|---------------|---------------|---------------|---------------|
| z12 [mm] | 27.5 | 28 | 36.5 | 45.5 | 50 | 61 | 71 | 78 |

Table 6.11.1–3: Distance dimension z12



Note.

Dimension z12 applies to standard assignment of the coupling. In the case of a special assignment, refer for the dimension to the relevant special dimension diagram.

- 3) Using the set screw, part 564, secure the coupling half, part 556, against axial displacement.
- 4) In the case of motors which are balanced with a half parallel key (symbol "H") machine off projecting and visible parts of the parallel key.

- 5) Insert the flexible element part 557 into the coupling half part 555.
- 6) Flange-mount the motor on the coupling housing and fasten it with the bolts, part 505, to the prescribed torque acc. to table 6.11.1–4 “Tightening torque T_A fitted motor”.

| Thread size | Tightening torque T_A strength class min. 8.8 [Nm] | Thread size | Tightening torque T_A strength class min. 8.8 [Nm] |
|-------------|--|-------------|--|
| M 4 | 3 | M 16 | 210 |
| M 5 | 6 | M 20 | 450 |
| M 6 | 10 | M 24 | 750 |
| M 8 | 25 | M 30 | 1500 |
| M 10 | 50 | M 36 | 2500 |
| M 12 | 90 | | |

Table 6.11.1–4: Tightening torque T_A fitted motor



Caution.

If drives are inadequately sealed, moisture may find a way in. If installing the drive outside or in the case of a higher type of protection (\geq IP 55): Seal flange, bolts, part 505, and any sealing plugs, part 502, provided or elements fitted, e.g. proximity switches, with a suitable sealing compound. Flange-mounted motors must generate a sealing surface running all the way round.

6.11.2 Using a clamp ring, attach standard motor to coupling housing

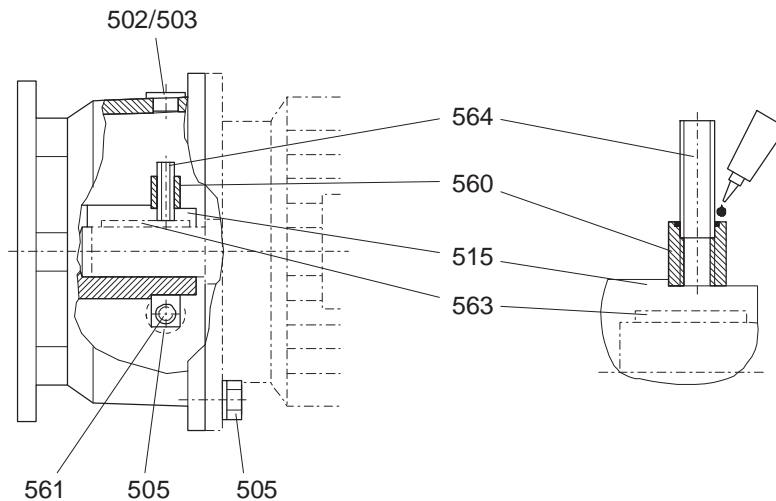

Figure 6.11.2–3: Coupling lantern with clamping ring

| | | |
|------------------------|-------------------------------|------------------|
| 502 Mounting plug | 515 Drive shaft | 563 Parallel key |
| 503 Mounting plug | 560 Clamp ring | 564 Set screw |
| 505 Hexagon head screw | 561 Hexagon socket head screw | |

- 1) Remove the mounting plugs part 502 and part 503.
- 2) Align drive shaft, part 515, and clamp ring, part 560, of the gear unit by turning to the mounting holes for mounting plugs, part 502 and part 503.
- 3) Coat the set screw, part 564, with adhesive (medium-strength, e.g. Loctite 243), see figure 6.11.2–3 “Coupling lantern with clamping ring”.
- 4) Fix clamp ring, part 560.



Caution.

Do not overstress the motor shaft axially when flange-mounting the motor. Keep the motor shaft completely grease-free in the area of the clamp ring. In the case of brake motors release the brake while flange-mounting.

- 5) Flange-mount the motor to the coupling housing and fasten it with the bolts, part 505, to the prescribed torque acc. to table 6.11.2–1 “Tightening torque T_A fitted motor”.

| Thread size | Tightening torque T_A strength class min. 8.8 [Nm] | Thread size | Tightening torque T_A strength class min. 8.8 [Nm] |
|-------------|--|-------------|--|
| M 4 | 3 | M 16 | 210 |
| M 5 | 6 | M 20 | 450 |
| M 6 | 10 | M 24 | 750 |
| M 8 | 25 | M 30 | 1500 |
| M 10 | 50 | M 36 | 2500 |
| M 12 | 90 | | |

Table 6.11.2–1: Tightening torque T_A fitted motor



Caution.

When pushing the motor onto the coupling, the motor bearing on the ventilation side may become overstressed. When fitting the motor in a vertical position from size 100 upwards the weight of the rotor shaft prevents the bearing from being overstressed. When fitting the motor in a horizontal position and for motors up to size 90, see work steps 6) - 8).

- 6) Remove the fan cover.
7) Ease the overstress on the bearing by lightly pressing the shaft end by hand, see figure 6.11.2–4 “Pressure on motor shaft”.

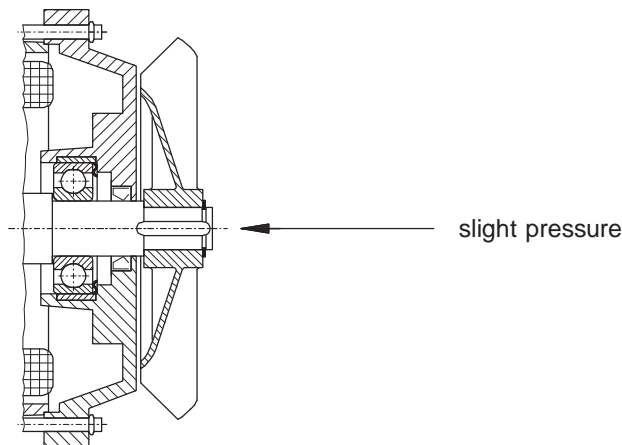

Figure 6.11.2–4: Pressure on motor shaft

- 8) Mount the fan cowl.
9) Screw the set screw, part 564, onto parallel key, part 563, until slight resistance is felt, then unscrew the set screw half a turn.
10) Insert the Allen key into set screw, part 564, through the hole for part 503. This prevents the shaft turning.



Caution.

Set screw, part 564, must not be in contact, of hexagon socket screw, part 561, has been tightened.

11) Tighten the hexagon socket screw, part 561, to tightening torque $T_{A\ SW2}$ acc. to table 6.11.2–2 “ T_A and SW”.

12) Tighten the set screw to tightening torque $T_{A\ SW1}$ acc. to table 6.11.2–2 “ T_A and SW” an.

| IEC B5 | 63 | 71 | 80 | 90 | 100 | 112 | 132 | 160 | 180 | 200 | 225 | 250 | 280 |
|-------------------|-----|-----|-----|-----|-----|-----|-----|-----|-----|-----|-----|-----|-----|
| $T_{A\ SW1}$ [Nm] | 1.3 | 1.3 | 1.3 | 2.9 | 2.9 | 2.9 | 5.8 | 9.9 | 9.9 | 9.9 | 9.9 | 9.9 | 48 |
| SW1 [mm] | 2 | 2 | 2 | 3 | 3 | 3 | 4 | 5 | 5 | 5 | 5 | 5 | 8 |
| $T_{A\ SW2}$ [Nm] | 15 | 15 | 15 | 35 | 35 | 35 | 70 | 120 | 120 | 295 | 295 | 295 | 580 |
| SW2 [mm] | 5 | 5 | 5 | 6 | 6 | 6 | 8 | 10 | 10 | 14 | 14 | 14 | 17 |

| NEMA TC | 56C | 143TC / 145TC | 182TC / 184TC | 213TC / 215TC |
|-------------------|-----|---------------|---------------|---------------|
| $T_{A\ SW1}$ [Nm] | 1.3 | 2.9 | 2.9 | 5.8 |
| SW1 [mm] | 2 | 3 | 3 | 4 |
| $T_{A\ SW2}$ [Nm] | 15 | 15 | 35 | 70 |
| SW2 [mm] | 5 | 5 | 6 | 8 |

Table 6.11.2–2: T_A and SW



Caution.

If drives are inadequately sealed, moisture may find a way in
 If installing the drive outside or in the case of a higher type of protection (\geq IP 55):
 Seal flange, bolts, part 505, and mounting plugs, part 502 and part 503, with a suitable sealing compound.
 Flange-mounted motors must generate a sealing surface running all the way round.

13) Seal the mounting holes with the plugs, part 502 and part 503.

6.12 Motor base plate



Drives in ATEX version.

The motor bedplate version is delivered without belt, belt pulley and safety cover.
 Sparks may be caused by friction or impact.
 A safety system must be used to ensure that
 - the belt does not slip and so become a source of combustion,
 - no foreign bodies can get into the belt drive zone.



Danger.

Rotating drive parts.
 Always fit suitable safety equipment to cover the belt, chain or other open drives.



Caution.

Belt breakage and bearing damage through incorrect belt tension.
 Observe operating instructions for V-belt drives.
 Fit belt pulleys onto the drive shaft, part 515, in accordance with section 6.6
 “Installation of input drive and output drive elements on gear unit shafts”.

The motor bedplate serves to mount an IEC-B3 foot-mounted motor used mainly to drive a V-belt drive.
 Fit the motor in accordance with the manufacturer’s operating instructions.

For other types of drive, e.g. chain drive, please observed the relevant operating instructions or manufacturer’s information.

6.12.1 Mounting IEC motors up to size 112

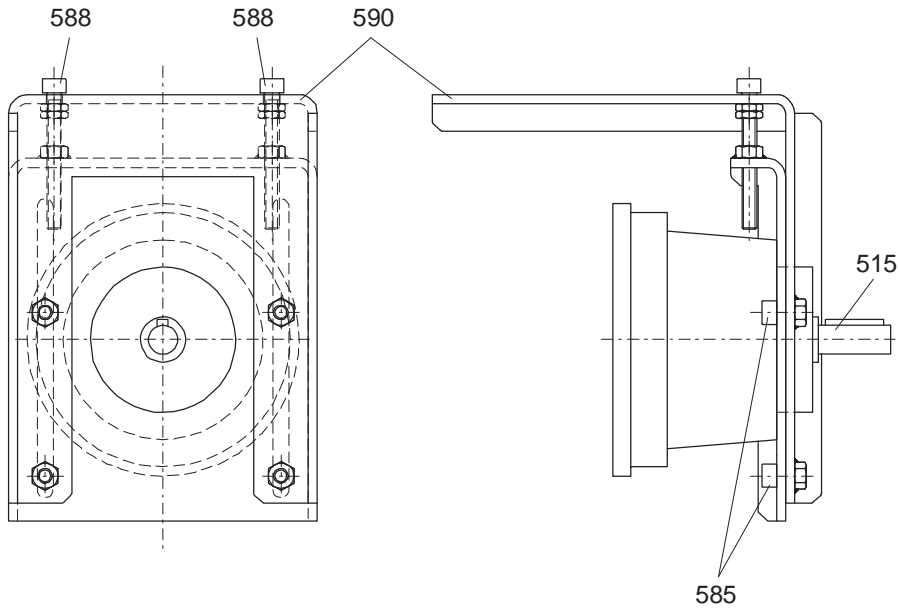

Figure 6.12.1: Mounting motor bedplates - IEC motors up to size 112

515 Drive shaft
585 Bolt

588 Bolt

590 Motor plate

- 1) Loosen the screw, part 585 (4x).
- 2) Adjust the height of the motor plate, part 590, by evenly turning the screw, part 588, and adjust e.g. the belt tension.
- 3) After adjusting to the correct height, tighten the bolts, part 585, (4x) to the prescribed torque acc. to table 6.12.1 "Tightening torque T_A fitted motor".

| Thread size | Tightening torque T_A strength class min. 8.8 [Nm] | Thread size | Tightening torque T_A strength class min. 8.8 [Nm] |
|-------------|--|-------------|--|
| M 4 | 3 | M 16 | 210 |
| M 5 | 6 | M 20 | 450 |
| M 6 | 10 | M 24 | 750 |
| M 8 | 25 | M 30 | 1500 |
| M 10 | 50 | M 36 | 2500 |
| M 12 | 90 | | |

Table 6.12.1: Tightening torque T_A fitted motor



Caution.

On completing installation and adjusting work protect bright parts against corrosion. Use a suitable, durable corrosion-preventive medium.

6.12.2 Mounting IEC motors sizes 132 to 200



Danger.
Motor bedplate may slip out of the fastening.
Do not adjust when in a suspended mounting position.

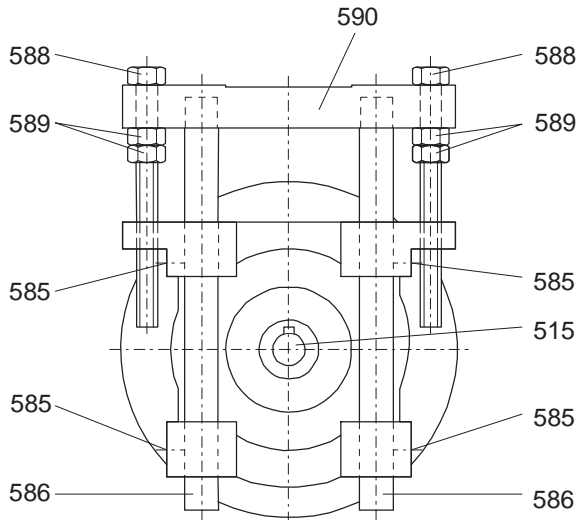

Figure 6.12.2: Mounting motor bedplate IEC motors sizes 132 to 200

| | | |
|-----------------|------------|-----------------|
| 515 Drive shaft | 586 Pillar | 589 Hexagon nut |
| 585 Set screw | 588 Bolt | 590 Motor plate |

- 1) Loosen the set screws Pos. 585 (4x).
- 2) Adjust the height of the motor plate, part 590, by evenly turning the screw, part 588, and adjust e.g. the belt tension.
- 3) After setting the correct height tighten the set screws, part 585, (4x).



Caution.
On completing installation and adjusting work protect bright parts against corrosion.
Use a suitable, durable corrosion-preventive medium.

6.12.3 Mounting IEC motors from size 225

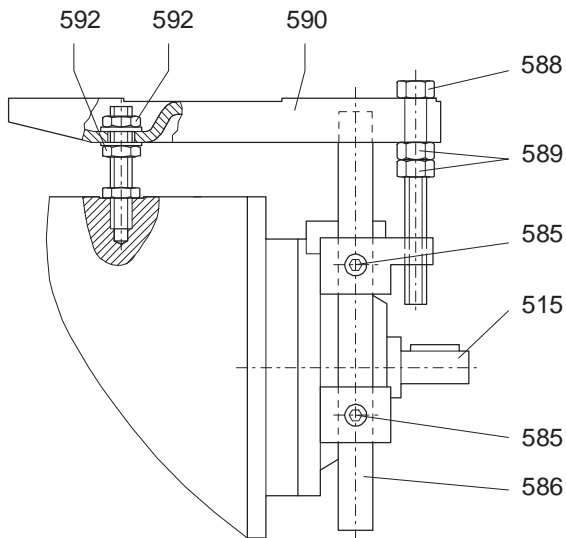

Figure 6.12.3: Mounting motor bedplate IEC motors from size 225

| | | |
|-----------------|-----------------|-----------------|
| 515 Drive shaft | 588 Bolt | 590 Motor plate |
| 585 Set screw | 589 Hexagon nut | 592 Hexagon nut |
| 586 Pillar | | |

- 1) Loosen the set screws Pos. 585 (4x).
- 2) Undo the hexagon nuts, part 592, of the support.
- 3) Adjust the height of the motor plate, part 590, by evenly turning the screw, part 588, and adjust e.g. the belt tension.
- 4) After setting the correct height tighten the set screws, part 585, (4x).



Caution.

When tightening the hexagon nuts, part 592, do not force or twist the motor plate, part 590, into a different position.

- 5) Tighten the hexagon nuts, part 592, of the support.

6.13 Torque arm with shaft-mounted gear units

The torque arm serves to absorb the reaction torque and, if necessary, the weight of the drive.



Drives in ATEX version.

Worn or irreparably damaged rubber elements will not function properly. Sparks may be caused by impact.

The rubber elements must be replaced immediately.



Caution.

Dangerously high impact moments due to too high backlash.

Ensure that the torque support does not give rise to excessive constraining forces (e.g. through the driven shaft running out of true).



Caution.

Keep solvents, oils, greases and fuels away from the rubber elements.

6.13.1 Fit torque arm to bevel helical gear unit



Danger.

The torque arm bush must be mounted in bearings on both sides.

Suggestion for fitting the gear unit with torque arm:

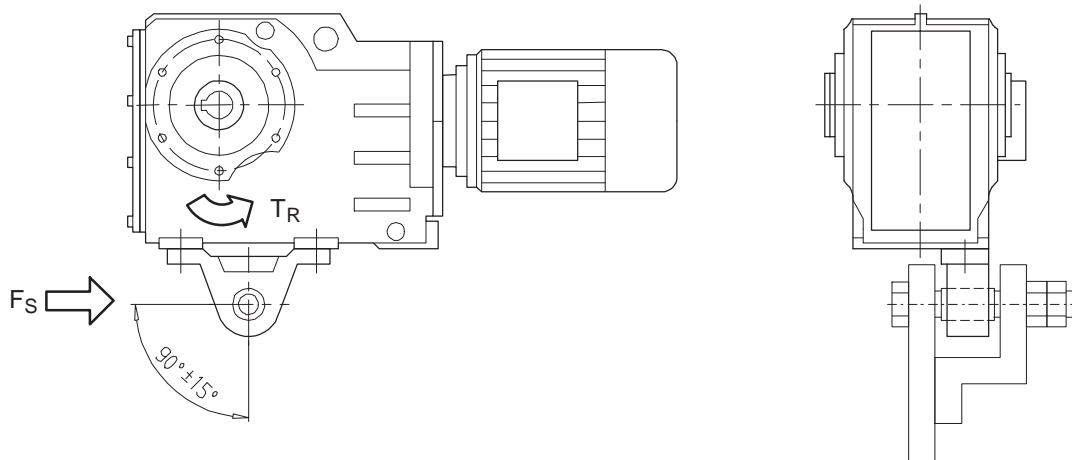

Figure 6.13.1: Torque arm on bevel helical gear unit

T_R Reaction torque on gear unit housing = output torque T_2

F_S Bracing force of the torque arm against the suspension

Properties of the rubber elements:

| | |
|-------------------------------|-------------------|
| Basic material natural rubber | 60 Shore A |
| thermal resistance | -45 °C ... +70 °C |

- 1) Clean the contact surfaces between housing and torque arm.
- 2) Secure the bolts for fastening the torque arm on the gear unit with Schnorr lock washers.
- 3) Tighten the bolts to the prescribed torque acc. to table 6.13.1 "Tightening torque T_A Fitting torque arm".

| Thread size | Tightening torque T_A strength class min. 8.8 [Nm] | Thread size | Tightening torque T_A strength class min. 8.8 [Nm] |
|-------------|--|-------------|--|
| M 8 | 25 | M 20 | 450 |
| M 10 | 50 | M 24 | 750 |
| M 12 | 90 | M 30 | 1500 |
| M 16 | 210 | | |

Table 6.13.1: Tightening torque T_A Fitting torque arm

6.13.2 Mounting torque arm on parallel shaft helical gear unit



Note.

We recommend using pretensioned, damping rubber elements.

Suggestion for fastening the rubber elements ordered from and supplied by us:

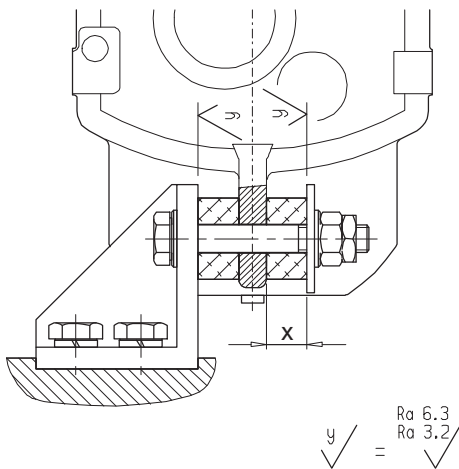

Figure 6.13.2: Torque arm on parallel shaft helical gear unit

Fixings such as angle, screw, nut etc. are not included in the delivery.

| Type | F.38B | F.48B | F.68B | F.88B | F.108B | F.128B | F.148B | F.168B | F.188B |
|--------|-------|-------|-------|-------|--------|--------|--------|--------|--------|
| x [mm] | 13.1 | 18.2 | 17 | 27.2 | 26 | 35.8 | 34.8 | 46.2 | 45.1 |

Table 6.13.2: Setting dimension x

Properties of the rubber elements:

Basic material natural rubber 70 Shore A
thermal resistance -40 °C ... +80 °C

6.13.3 Mounting torque arm on helical worm gear unit



Danger.

The torque arm bush must be mounted in bearings on both sides.

Suggestion for fitting the gear unit with torque arm:

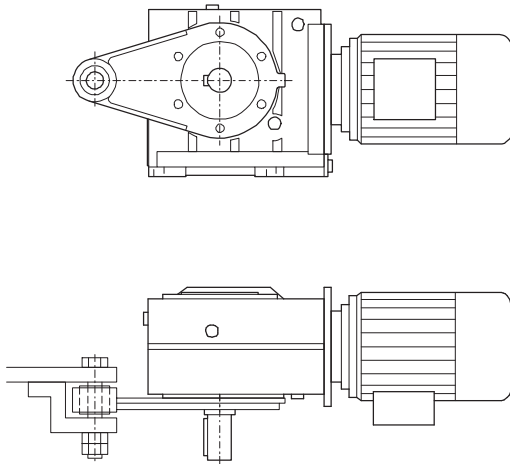

Figure 6.13.3: Torque arm on helical worm gear unit

The torque arm may be fitted in various positions, depending on the hole circle pitch.

Properties of the rubber elements:

Basic material natural rubber 60 Shore A
thermal resistance -45 °C ... +70 °C

- 1) Clean the contact surfaces between housing and torque arm.
- 2) Tighten the bolts to the prescribed torque acc. to table 6.13.3 "Tightening torque T_A Fitting torque arm".

| Thread size | Tightening torque T_A strength class min. 8.8 [Nm] | Thread size | Tightening torque T_A strength class min. 8.8 [Nm] |
|-------------|--|-------------|--|
| M 8 | 25 | M 20 | 450 |
| M 10 | 50 | M 24 | 750 |
| M 12 | 90 | M 30 | 1500 |
| M 16 | 210 | | |

Table 6.13.3: Tightening torque T_A Fitting torque arm

7. Start-up



Danger.

Secure the drive unit to prevent it from being started up unintentionally. Attach a warning notice to the start switch.



Danger.

Remove any oil spillage immediately with an oil-binding agent in compliance with environmental requirements.

7.1 Oil level check before start-up

Check the oil level before starting up, rectify the oil level, if necessary.



Note.

Description of the work see section 10.2.1 "Oil level".

7.2 Fill in oil

If the gear unit has been delivered without oil, put in lubricant before starting up.



Note.

Description of the work see section 10.2.3 "Oil change".

7.3 Ventilation of the gear unit

7.3.1 Filter for ventilation or pressure relief valve without securing clip

In the case of gear units with required housing ventilation the necessary ventilation filter or pressure relief valve without a securing clip is delivered separately. They must be replaced with the appropriate screw plug before starting up the gear unit.



1) Unscrew the sealing element at the point marked with this symbol, see section 3.5 "Mounting positions".

2) Seal the gear unit with the ventilation filter or the pressure relief valve without securing clip..

7.3.2 Pressure relief valve with securing clip (special version)

In the case of gear units with the required housing ventilation the pressure relief valve is fitted.

Remove the transport fixture by pulling the securing clip in the direction of the arrow.

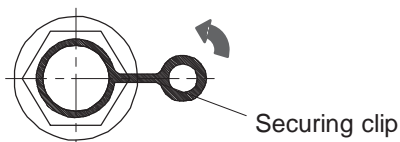

7.4 Start-up after long-term preservation

7.4.1 Long-term preservation up to 18 months

The gear unit is preserved internally, but delivered without oil.



Caution.

Before starting up fill the gear unit with lubricant, see section 10.2.3 "Oil change".

7.4.2 Long-term preservation up to 36 months

The gear unit is delivered with a complete oil filling.



Caution.

Before starting up adjust oil level in accordance with the assembly option, see section 3.5 "Mounting positions".



1) Unscrew the sealing element at the point marked with this symbol, see section 3.5 "Mounting positions" and drain the oil.

2) Check the oil level.

3) Rectify the oil level, if necessary, see section 10.2.3 "Oil change", and check it again.

7.5 Drive with backstop (special version)



Caution.

Before starting up check direction of rotation.

Turn drive side or motor over manually.

Check direction of motor rotation with the aid of the phase sequence. If necessary, exchange two outer conductors.

8. Operation



Drives in ATEX version.

The difference between the temperature of the housing and the ambient temperature (max. 40 °C) must not exceed 70 K.

Using a suitable temperature sensor, measure the temperature at the lowest point of the housing (oil sump) or at the mounting surface in the case of output assemblies. Changes are an indication of possible incipient damage.



Caution.

In case of changes during operation the drive must be switched off immediately.

Determine the cause of the fault with the aid of the fault table in section 9. "Faults, causes and remedy".

Remedy faults or have faults remedied.

Check the gear unit during operation for:

- excessive operating temperature
- changes in gear noise
- possible oil leakage at the housing and shaft seals.

9. Faults, causes and remedy



Note.

Faults and malfunctions occurring during the guarantee period and requiring repair work on the drive must be carried out only by **FLENDER TÜBINGEN GMBH** Customer Service. In the case of faults and malfunctions occurring after the guarantee period and whose cause cannot be precisely identified, we advise our customers to contact our customer service.

If you need the help of our customer service, please state the following:

- data on the rating plate
- kind and extent of the fault
- suspected cause.

| Malfunctions | Causes | Remedy |
|----------------------------------|--|---|
| Unusual noises on the gear unit | oil level too low | check oil level, see section 10.2.1 "Oil level". |
| | foreign bodies in oil (irregular noise) | stop drive. Check oil quality. Clean drive. Change oil, see section 10.2.2 "Oil quality". |
| | excessive bearing play and/or bearing defective | check and, if necessary, replace bearings. |
| | teeth defective | check teeth and, if necessary, replace. |
| | fastening bolts loose | tighten bolts / nuts, see section 10.2.10 "Checking tightness of fastening bolts". |
| | excessive load on drive and output | check load on rating data. E.g. adjust belt tension. |
| | transport damages | check drive for transport damage. |
| | damage through blocking during start-up | contact customer service. |
| Unusual noises on the drive unit | bearing of drive unit not lubricated (from motor size 160 upwards) | relubricate bearing, see section 10.2.5 "Relubrication of the rolling bearings in drive units". |
| | excessive bearing play and/or bearing defective | check and, if necessary, replace bearings. |
| | fastening bolts loose | tighten bolts / nuts, see section 10.2.10 "Checking tightness of fastening bolts". |
| Unusual noises on the motor | excessive bearing play and/or bearing defective | check and, if necessary, replace bearings. |
| | motor brake rubbing | check, and if necessary adjust lifting gap. |
| | inverter parametrisation | correct parametrisation. |

| Malfunctions | Causes | Remedy |
|---|--|---|
| Oil leak | incorrect oil level for assembly option used | check assembly option, see section 3.5 "Mounting positions". Check oil level, see section 10.2.1 "Oil level". |
| | overpressure due to lack of ventilation | mount ventilation acc. to mounting position, see section 3.5 "Mounting positions". |
| | overpressure due to soiled ventilation | clean ventilation system, see section 10.2.8 "Clean ventilation filter". |
| | shaft sealing rings defective | replace shaft sealing rings. |
| | cover / flange bolts loose | tighten bolts / nuts, see section 10.2.10 "Checking tightness of fastening bolts". Continue observation of drive unit. |
| | surface sealing defective (e.g. on cover, flange) | reseal. |
| | transport damage (e.g. microcracks) | check drive for transport damage. |
| Oil leakage on gear-unit ventilation | incorrect oil level for the assembly option used and/or incorrect ventilation position | check position of ventilation and assembly option, see section 3.5 "Mounting positions". Check oil level, see section 10.2.1 "Oil level". |
| | frequent cold starts, during which the oil foams up | contact customer service. |
| Gear unit overheating | motor fan cover and/or drive badly soiled | clean fan cover and surface of drive, see section 10.2.9 "Clean drive". |
| | incorrect oil level for assembly option used | check assembly option, see section 3.5 "Mounting positions". Check oil level, see section 10.2.1 "Oil level". |
| | incorrect oil being used (e.g. incorrect viscosity) | check oil used, see section 10.2.2 "Oil quality". |
| | oil too old | check date of last oil change. Change oil, see section 10.2.3 "Oil change". |
| | excessive bearing play and/or bearing defective | check and, if necessary, replace bearings. |
| | backstop not running freely | replace backstop. |
| Output shaft does not turn when motor is running. | force flow interrupted by breakage in the gear unit | contact customer service. |

| Malfunctions | Causes | Remedy |
|--|---|---|
| Drive does not run or starts with difficulty | incorrect oil level for assembly option used | check assembly option, see section 3.5 "Mounting positions". Check oil level, see section 10.2.1 "Oil level". |
| | incorrect oil being used (e.g. incorrect viscosity) | check oil used, see section 10.2.2 "Oil quality". |
| | excessive load on drive and output | check load on rating data. E.g. adjust belt tension. |
| | motor brake is not lifted | check switching/connection of brake. Check brake for wear. If necessary, readjust brake. |
| | drive runs against backstop | change direction of motor or backstop rotation. |
| Excessive play on drive and output | flexible elements worn (e.g. with couplings) | replace flexible elements. |
| | positive connection disrupted by overload | contact customer service. |
| Drop of speed or torque | belt tension too low (in case of belt drive). | check belt tension, replace belt, if necessary. |

Table 9.: Faults, causes and remedy

10. Maintenance and repair

10.1 General information for maintenance

All inspection, maintenance and repair work must be done with care by trained and qualified personnel only. Observe the instructions given in section 2. "Safety instructions".



Drives in ATEX version.

All measures and checks and their results must be documented by the operator and kept in a safe place.

Maintenance and servicing must be carried out only by properly trained, authorised personnel. Only parts supplied by **FLENDER TÜBINGEN GMBH** must be used for servicing.

| Measure | Interval | Description of work |
|--|--|---|
| Observe and check drive unit for unusual noises, vibrations or changes | daily; if possible, more frequently during operation | see section 8. "Operation". |
| Check housing temperature | after 3 h, 1 day, then monthly | |
| Checking oil level | after the 1st day, then monthly | see section 10.2.1.1 "Check the oil level in the gear housing". |
| Checking the function of the oil sensor | regularly and after oil change | see section 10.2.1.4 "Checking the oil level sensor". |
| Checking the oil quality | every 6 months | see section 10.2.2 "Oil quality". |
| First oil change after start-up | after approx. 10 000 operating hours, at the latest after 2 years. | see section 10.2.3 "Oil change". |
| Subsequent oil changes | every 2 months or 10 000 operating hours | |
| Checking gear unit for leaks | after the 1st day, then monthly | see section 10.2.7 "Seal check". |
| Clean ventilation and, if necessary, replace | depending on degree of soiling, at least every 6 months. | see section 10.2.8 "Clean ventilation filter". |
| Clean drive | | see section 10.2.9 "Clean drive". |
| Check, and if necessary adjust slip coupling | every 12 months at least | see section 10.2.12 "Carry out maintenance on slip coupling". |
| Check coupling | for first time after 3 months | Observe the separate operating instructions. |
| Carrying out complete inspection of drive unit | every 12 months | see section 10.2.11 "Inspection of the drive". |
| Check that fastening bolts of gear unit and mounted elements are securely tightened. Check that covers and sealing plugs are securely fastened | after 3 h, then at regular intervals. | see section 10.2.10 "Checking tightness of fastening bolts". |

| Measure | Interval | Description of work |
|---|---|--|
| Relubricating the rolling bearings in drive units | at least every 12 months or every 4 000 operating hours | see section 10.2.5 "Relubrication of the rolling bearings in drive units". |
| Change rolling bearing grease | along with oil change | see section 10.2.6 "Change rolling bearing grease". |
| Replace bearing | - | see section 10.2.4 "Replacing bearings". |
| Checking rubber buffers of torque arm | every 6 months | see section 6.13 "Torque arm with shaft-mounted gear units". |

Table 10.1: Maintenance measures

10.2 Description of maintenance and repair work

10.2.1 Oil level



Drives in ATEX version.

After the screw plug has been removed, the oil level may not be more than 3 mm (in the case of 3/8" hole) or 5 mm (in the case of 3/4" hole) below the minimum filling level.



Danger.

Secure the drive unit to prevent it from being started up unintentionally. Attach a warning notice to the start switch.



Danger.

Danger of scalding from the hot oil emerging.
Before starting any work wait until the oil has cooled down to 30 °C.



Danger.

Remove any oil spillage immediately with an oil-binding agent in compliance with environmental requirements.



Caution.

The oil quantity and the position of the sealing elements depend upon the assembly option, see section 3.5 "Mounting positions".



Note.

As a rule, mineral oil is used as lubricant. Synthetic oils with special properties are available optionally.

For data such as oil grade, oil viscosity and oil quantity required, refer to the rating plate, see section 3.2 "General technical data".

For oil compatibility refer to, see section 10.3 "Lubricants".



Note.

In case of double gear units every single unit is to be considered separately.

10.2.1.1 Check the oil level in the gear housing

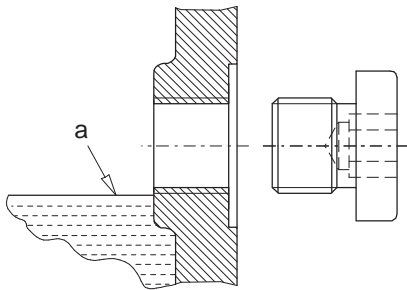

Figure 10.2.1.1-1: Oil level

a Oil level

1) Switch off the power supply to the drive.



2) Unscrew the sealing element at the point marked with this symbol, see section 3.5 "Mounting positions".

3) Check the oil level.

4) Rectify the oil level, if necessary, see section 10.2.3 "Oil change", and check it again.

5) Check the condition of the sealing ring on the sealing element; if necessary, replace the sealing ring.

6) Seal the gear unit with the sealing element.

Check the oil level in the gear housing size 38

Size 38 gear units have no screw plug for checking the oil level.

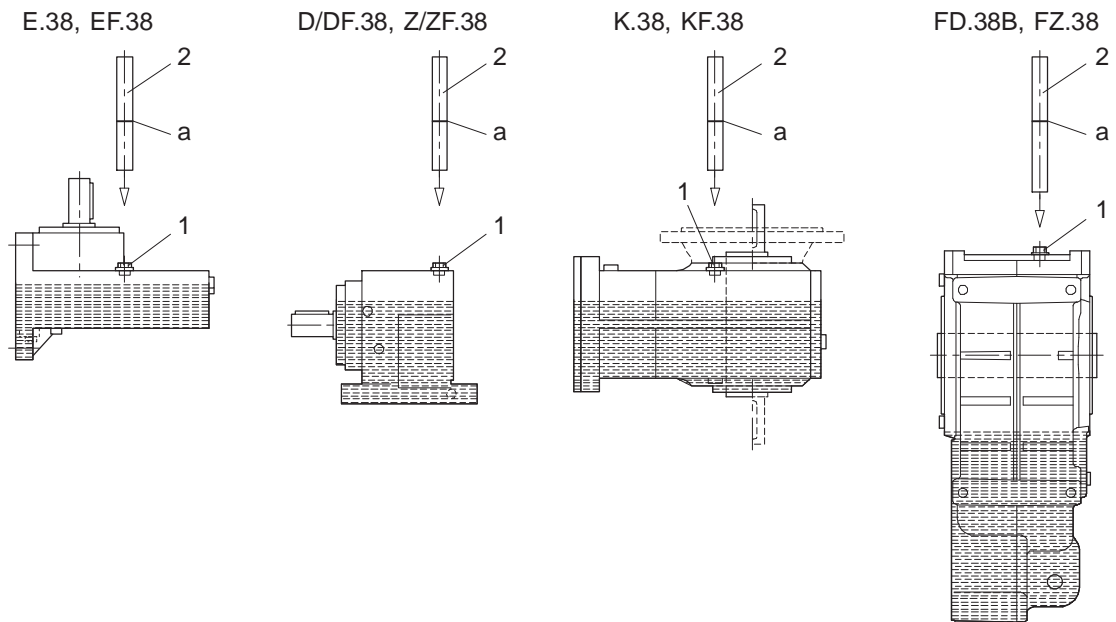

Figure 10.2.1.1-2: Oil level check on size 38 gear unit

1) Switch off the power supply to the drive.

2) Demount the drive and set it up in accordance with figure 10.2.1.1-2 "Oil level check on size 38 gear unit". The screw plug, part 1, must be on the upward side.

3) Unscrew the plug, part 1.

- 4) Put a mark (a) on a suitable dipstick, part 2.
- 5) Insert the dipstick, part 2, vertically through the hole until the mark (a) is level with the surface of the gear unit.
- 6) Pull the dipstick, part 2, out vertically.
- 7) Measure the distance "x" on the dipstick, see figure 10.2.1.1–3 "Distance "x"".

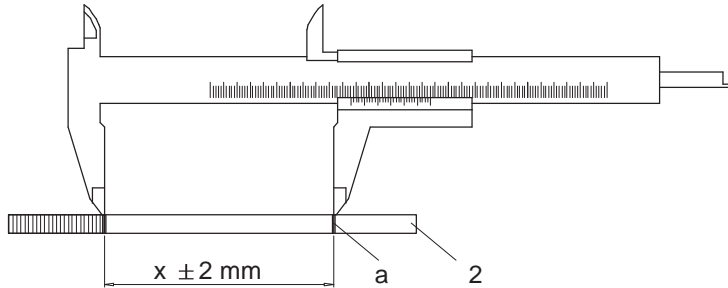

Figure 10.2.1.1–3: Distance "x"

- 8) Compare value "x" with the value acc. to table 10.2.1.1 "Values for distance "x"".

| Type | max. distance "x" between oil level and marking on oil dipstick [mm] | | | | | |
|--------|---|---------------|---------------|---------------|---------------|---------------|
| | B3 | B6 | B7 | B8 | V5 | V6 |
| E.38 | 43 | 37 | 37 | 31 | 23 | 19 |
| Z.38 | 93 | 83 | 83 | 83 | 75 | 32 |
| D.38 | 89 | 82 | 82 | 82 | 52 | 35 |
| | B5 B14 | V1 V18 | V3 V19 | | | |
| EF.38 | 44 | 24 | 18 | | | |
| ZF.38 | 87 | 56 | 33 | | | |
| DF.38 | 81 | 31 | 26 | | | |
| | B3-00 H-01 | B8-00 H-02 | B7-00 H-03 | B6-00 H-04 | V5-00 H-05 | V6-00 H-06 |
| K.38 | 64 | 35 | 21 | 52 | 40 | 46 |
| | B5-01 H-01 | B5-03 H-02 | B5-02 H-03 | B5-00 H-04 | V1-00 H-05 | V3-00 H-06 |
| KF.38 | 66 | 40 | 20 | 54 | 45 | 50 |
| | B5-01 H-01 | B5-03 H-02 | B5-02 H-03 | B5-00 H-04 | V1-00 H-05 | V3-00 H-06 |
| FZ.38B | 137 | 152 | 137 | 137 | 87 | 73 |
| FD.38B | 110 | 147 | 132 | 132 | 110 | 65 |

Table 10.2.1.1: Values for distance "x"

- 9) Rectify the oil level, if necessary, see section 10.2.3 "Oil change", and check it again.
- 10) Check the condition of the sealing ring on the sealing element; if necessary, replace the sealing ring.
- 11) Seal the gear unit with the sealing element, part 1.
- 12) Mount the drive.

10.2.1.2 Checking the oil level by the oil sight glass (special version)

In the case of the oil sight glass the oil level must be in the middle of the sight glass.

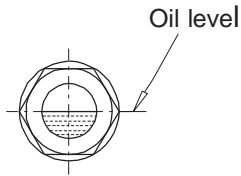

Figure 10.2.1.2: Oil level in the oil sight glass

Rectify the oil level, if necessary, see section 10.2.3 “Oil change“, and check it again.

10.2.1.3 Checking the oil level by the oil dipstick (special version)

Measure the oil level with the dipstick resting on the hole but not screwed in.

The oil level must be between the lower and upper (min. - max.) marks on the oil dipstick.

If the electric oil level monitoring system is used, the oil must be level with the upper (max.) mark on the oil dipstick.

Rectify the oil level, if necessary, see section 10.2.3 “Oil change“, and check it again.

10.2.1.4 Checking the oil level sensor (special version)



Drives in ATEX version.

The oil level sensor indicates the oil level only when the gear unit is shut off.

Lower the oil level and fill it up again until the oil level sensor gives a switching signal.

Observe the separate operating instructions for the oil level sensor.

10.2.2 Oil quality

1) Switch off the power supply to the drive.



2) Unscrew the sealing element at the point marked with this symbol, see section 3.5 “Mounting positions” and take a small sample of oil.

3) Check the condition of the sealing ring on the sealing element; if necessary, replace the sealing ring.

4) Seal the gear unit with the sealing element.

5) Signs of changes in the oil can be seen with the naked eye. Fresh oil is clear to the eye and has a typical smell and a specific product colour. Clouding or a flocculent appearance indicate water and/or contamination. A dark or black colour indicates residue, severe thermal decomposition or contamination. If you detect such abnormalities, the oil must be changed immediately.

6) Check the oil level.

7) Rectify the oil level, if necessary, see section 10.2.3 “Oil change“, and check it again.

10.2.3 Oil change



Danger.

Secure the drive unit to prevent it from being started up unintentionally. Attach a warning notice to the start switch.



Danger.

Danger of scalding from the hot oil emerging.
Before starting any work wait until the oil has cooled down to 30 °C.



Danger.

Remove any oil spillage immediately with an oil-binding agent in compliance with environmental requirements.



Caution.

The oil quantity and the position of the sealing elements depend upon the assembly option, see section 3.5 "Mounting positions".



Note.

As a rule, mineral oil is used as lubricant. Synthetic oils with special properties are available optionally.

For data such as oil grade, oil viscosity and oil quantity required, refer to the rating plate, see section 3.2 "General technical data".

For oil compatibility refer to, see section 10.3 "Lubricants".



Note.

In case of double gear units every single unit is to be considered separately.



Note.

In case of ambient conditions deviating from the normal (high ambient temperatures, high relative humidity, aggressive ambient media), the intervals between changes should be shorter. In such cases contact the **FLENDER TÜBINGEN GMBH** customer service to determine the individual lubricant change intervals.

Draining the oil



Note.

The oil must be warm, as too cold oil will flow too sluggishly to drain properly. If necessary, allow gear unit to run for 15 - 30 minutes to warm up.

- 1) Switch off the power supply to the drive.



- 2) Unscrew the sealing element at the point marked with this symbol, see section 3.5 "Mounting positions".



- 3) Unscrew the sealing element at the point marked with this symbol, see section 3.5 "Mounting positions".

- 4) Place a sufficiently large, suitable receptacle under the oil drainage plug.



- 5) Unscrew the sealing element at the point marked with this symbol, see section 3.5 "Mounting positions" and completely drain off the oil into the receptacle.

- 6) Check the condition of the sealing ring on the sealing element; if necessary, replace the sealing ring.

- 7) Seal the gear unit with the sealing element.

Fill in oil



- 1) Unscrew the sealing element at the point marked with this symbol, see section 3.5 "Mounting positions".

- 2) Fill the gear unit with fresh oil, using a filter (max. mesh 25 µm). When refilling, use the same type of oil with the same viscosity.

- 3) Check the oil level.

- 4) Rectify the oil level, if necessary, see section 10.2.3 "Oil change", and check it again.

- 5) Check the condition of the sealing ring on the sealing element; if necessary, replace the sealing ring.

- 6) Seal the gear unit with the sealing element.

10.2.4 Replacing bearings



Drives in ATEX version.

The bearing life depends very much on the operating conditions. It is therefore very difficult to calculate it reliably. If the operating conditions are specified by the operator, the bearing life can be calculated and indicated on the rating plate. If no information is given, changes in the vibration and noise pattern can serve as an indication that an immediate bearing replacement is necessary.

10.2.5 Relubrication of the rolling bearings in drive units



Caution.

When relubricating, do not mix greases with different soap bases.

Relubricating the drive units is required from motor size 160 upwards.

The bearings have already been initially greased.

The standard lubricating grease used is a mineral-oil-based lithium-saponified grease of NLGI class 3, see table 10.3–2 “Rolling bearing greases“.

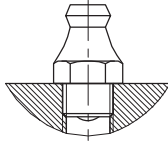

Using a grease gun, inject the grease into the bearing point via the lubricating nipples provided. Inject 50 g grease per lubricating point, unless otherwise specified in the vicinity of the lubricating point.

Figure 10.2.5: Grease nipple

10.2.6 Change rolling bearing grease

The rolling bearings have been filled with a lithium-saponified rolling bearing grease at the factory.

Clean the bearing before filling it with fresh lubricant.

In the case of the bearings of the output shaft or intermediate shafts the grease quantity must fill 2/3 and in the case of bearings on the input side 1/3 of the space between the bearing bodies.

10.2.7 Seal check

Oil or grease escaping in small quantities (a few drops) from the shaft sealing ring must be regarded as normal during the running-in phase (24 hours running time).

If the quantities escaping are great or leakage continues after the running-in phase, the shaft sealing ring must be replaced to prevent consequential damage.

Because of its structure and function a shaft sealing ring is subject to natural wear. The service life depends on the operating conditions. It is recommended that the shaft sealing rings be included in the periodic maintenance and servicing work on the system.

10.2.8 Clean ventilation filter

Clean the ventilation filter, depending on the degree of soiling - at least every 6 months.

- 1) Unscrew the ventilation filter.
- 2) Flush out the ventilation filter with petroleum ether or a similar cleaning agent.
- 3) Blow the ventilation filter out with compressed air.
- 4) Seal the gear unit with the ventilation filter.

10.2.9 Clean drive



Drives in ATEX version.

Dust deposits prevent heat radiation and cause high housing temperatures. Keep the drive free from dirt and dust.



Caution.

Do not use a high-pressure cleaning appliance to clean the drive.
Do not use tools with sharp edges.

Switch off the power supply to the drive before cleaning it.

10.2.10 Checking tightness of fastening bolts



Drives in ATEX version.
Loose parts can cause sparks through impact.
Entry of foreign bodies may cause sparks.



Note.
Damaged headless screws must be replaced with new screws of the same type and strength class.

- 1) Switch off the power supply to the drive.
- 2) Using a torque wrench, check that all fastening bolts are correctly tightened for torque, acc. to table 10.2.10 "Tightening torques T_A - fastening bolts".

| Thread size | Tightening torque T_A | |
|-------------|-------------------------|----------------|
| | Strength class | Strength class |
| | 8.8 [Nm] | 10.9 [Nm] |
| M 4 | 3 | 4 |
| M 5 | 6 | 9 |
| M 6 | 10 | 14 |
| M 8 | 25 | 35 |
| M 10 | 50 | 70 |
| M 12 | 90 | 120 |
| M 16 | 210 | 295 |
| M 20 | 450 | 580 |
| M 24 | 750 | 1000 |
| M 30 | 1500 | 2000 |
| M 36 | 2500 | 3600 |

Table 10.2.10: Tightening torques T_A - fastening bolts

10.2.11 Inspection of the drive

Routinely inspect the drive once a year in accordance with the possible criteria listed in section 9. "Faults, causes and remedy".

Check the drive in accordance with the criteria set out in section 2. "Safety instructions".

Touch up damaged paintwork carefully.

10.2.12 Carry out maintenance on slip coupling



Note.
Check the condition of the slip clutch initially after 500 operating hours and then at least once yearly and after every blockage of the machine.

If necessary, readjust the slip torque or replace the wearing parts (friction lining and bushes). Friction linings must always be replaced in pairs. We recommend replacing worn bushes in sets.

For this, please observe the relevant operating instructions for the clutch.

10.3 Lubricants



Danger.

The listed lubricants are not approved under USDA -H1 / -H2 (United States Department of Agriculture). They are not or only conditionally approved for use in the foodstuffs or pharmaceutical industry. If lubricants with USDA -H1 / -H2 approval are required, please contact the **FLENDER TÜBINGEN GMBH** customer service.



Caution.

When changing oil of the same type, the quantity of oil remaining in the gear unit should be kept as low as possible. Generally speaking, a small remaining quantity will cause no particular problems.

Gear oils of different types and manufacturers must not be mixed. If necessary, the manufacturer should confirm that the new oil is compatible with residues of the used oil.

If changing very different types of oil or oils with very different additives, always flush out the gear unit with the new oil. This applies particularly when changing from polyglycols (PG) to another gear oil or vice versa. Residues of used oil must be completely removed from the gear unit.



Caution.

Gear oils must never be mixed with other substances. Flushing with paraffin or other solvents is not permitted, as traces of these substances always remain inside the unit.



Caution.

If applications are outside the temperature ranges specified in the table 10.3–1 “Oils” likewise contact the **FLENDER TÜBINGEN GMBH** customer service with regard to the choice of oil.

If due to its mounting position or load the temperature of the gear unit rises above +80 °C, contact the **FLENDER TÜBINGEN GMBH** customer service with regard to the choice of a suitable synthetic lubricant.



Note.

The lubricants are not or are only conditionally biodegradable. If lubricants are required in accordance with these classifications, please contact the **FLENDER TÜBINGEN GMBH** customer service.



Note.

These recommendations are not a guarantee of the quality of the lubricant supplied by your supplier. Each lubricant manufacturer is responsible for the quality of his own product.

The oil selected for use in the gear unit must be of the viscosity (ISO VG class) stated on the rating plate. The viscosity class indicated applies for the contractually agreed operating conditions.

In the case of different operating conditions contact with **FLENDER TÜBINGEN GMBH** is required.

The lubricants suitable for use in the gear unit are listed in table 10.3–1 “Oils” and table 10.3–2 “Rolling bearing greases”.

We are familiar with the composition of these lubricants and, as far as we are currently aware, they possess the properties acc. to state of the art with regard to load-bearing capacity, corrosion resistance (FZG-Test DIN 51354 = force level > 12), resistance to grey staining and compatibility with seals and interior paint coats which are necessary for the type of gear unit concerned.

We therefore advise our customers to select one of the lubricants listed in this table, taking into account the VG class specified on the nameplate.

If by agreement gear units are filled at the factory with special lubricants for the above mentioned special applications, this is shown on the rating plate, e.g.: CLP-H1 VG220 or CLP E VG220.

The guarantee specifications are valid only for the lubricants shown in these operating instructions.

Service life of the lubricants



Note.

If oil sump temperatures exceed +80 °C, the service life may also be lower than shown in figure 10.3 "Approximate values for oil-change intervals". The general rule is that an increase in temperature by 10 K will halve the service life.



Note.

In the case of rolling bearings with grease filling we recommend changing the grease filling as well when changing the oil.

With an oil sump temperature of +80 °C the following service life with adherence to the characteristics required by **FLENDER TÜBINGEN GMBH** is expected:

- 1) Mineral oil
 Biologically degradable oil
 Physiologically safe oil (USDA -H1 / -H2) 10 000 operating hours or 2 years
- 2) Synthetic oil (PG) 20 000 operating hours or 4 years

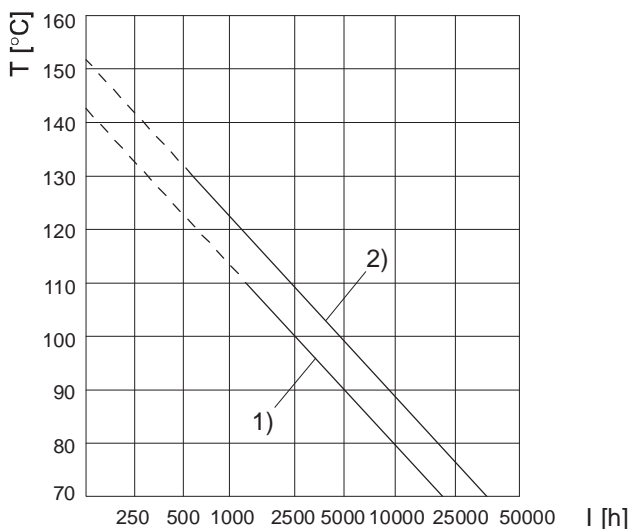

Figure 10.3: Approximate values for oil-change intervals

T Oil-bath steady-state temperature [°C]
 I Oil-change interval in operating hours [h]











| | Mineral oil | Synthetic oil (PG) / Polyglycol (PG) | |
|---|--|--------------------------------------|----------------------------------|
| Designation to DIN 51 502 | CLP ISO VG 220 | CLP PG ISO VG 220 | CLP PG ISO VG 460 |
| Gear-unit types | E., D./Z., K., F. | E., D./Z., K., F., C. | |
| Ambient temperatures | -10 °C ... +40 °C | -20 °C ... +50 °C | 0 °C ... +60 °C |
|  | CLP 220 S | | |
|  | Degol BG 220 | Degol GS 220 | Degol GS 460 |
|  | Energol GR-XP 220 | Energol SG-XP 220 | Energol SG-XP 460 |
|  | Alpha SP 220 Optigear BM 220 Tribol 1100/220 | Optiflex A 220 Tribol 800/220 | Optiflex A 460 Tribol 800/460 |
|  | Falcon CLP 220 | Polydea PGLP 220 | Polydea PGLP 460 |
|  | Spartan EP 220 | Glycolube 220 | Glycolube 460 |
|  | Renolin CLP 220 | Renolin PG 220 | Renolin PG 460 |
|  | Klüberoil GEM 1-220 | Syntheso D 220 EP | Syntheso D 460 EP |
|  | Mobilgear XMP 220 | | |
|  | Omala 220 | Tivela WB | Tivela SD |

Table 10.3-1: Oils



Note.

The service life of the grease is approx. 4.000 operating hours. It is based on a max. ambient temperature of +40 °C. The service life of the grease decreases by a factor of 0.7 for every 10 K rise in temperature.

| | Lithium-saponified greases NLGI 3/2 |
|---|--|
|  | Aralub HL3, HL2 |
|  | Energrease LS3, LS2 |
|  | Longtime PD2 TRIBOL 4020/220-2 |
|  | Glissando 30, 20 |
|  | Beacon 3 |
|  | Renolit FWA160, FWA220 |
|  | Centroplex GLP402 |
|  | Mobilux 3, 2 |
|  | Alvania RL3, RL2 |
|  | Wiolub LFK2 |

Table 10.3–2: Rolling bearing greases

11. Disposal

Dispose of the housing parts, gears, shafts and rolling bearings as steel scrap.

This also applies to grey cast iron parts, if no separate collection is made.

The worm wheels are made partly from non-ferrous metal. Dispose of them accordingly.



Danger.

Incorrect disposal of used oil is a threat to the environment and health.

After use the oil must be taken to a used oil collection point. Any addition of foreign material such as solvents and brake and cooling fluid is prohibited.

Avoid prolonged contact with the skin.

Collect and dispose of used oil in accordance with regulations.

Remove any oil spillage immediately with an oil-binding agent in compliance with environmental requirements.

12. Stocking spare parts and customer service addresses

12.1 Stocking spare parts

By stocking the most important spare and wearing parts on site you can ensure that the drive is ready for use at any time.



Caution.

Please note that spare parts and accessories not supplied by us have not been tested or approved by us.



The installation and/or use of such products may therefore impair essential characteristics of the drive, thereby posing an active or passive risk to safety.

FLENDER TÜBINGEN GMBH will assume no liability or guarantee for damage caused by spare parts and accessories not supplied by **FLENDER TÜBINGEN GMBH**.

We guarantee only the original spare parts supplied by us.

Please note that certain components often have special production and supply specifications and that we always supply you with spare parts which comply fully with the current state of technical development as well as current legislation.

When ordering spare parts, always state the following:

- Order no. (see rating plate )
- Type designation (see rating plate )
- Part no. (3-digit part no. from spare parts list, 6-digit code no. or 7-digit article no.)
- Quantity

12.2 Spare parts lists

12.2.1 One-stage helical gear units

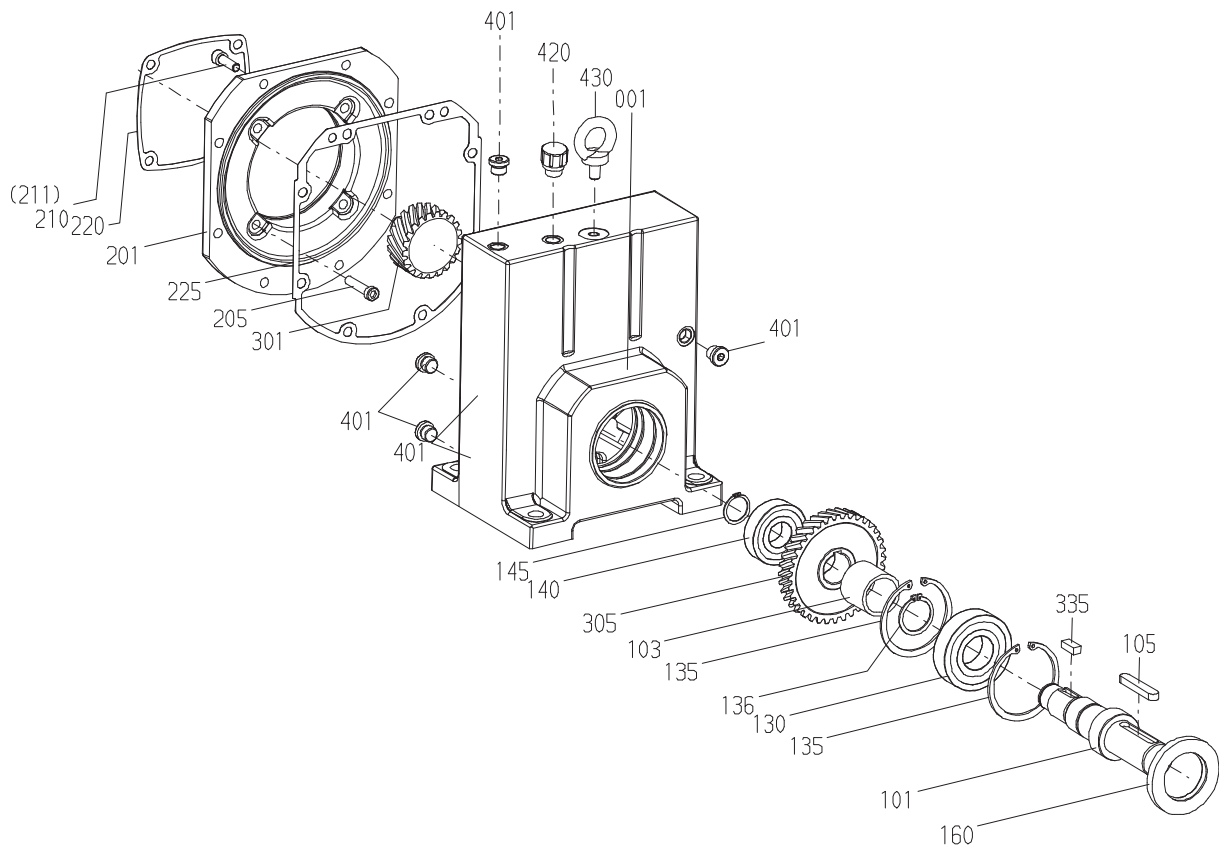

| | | |
|-----------------------|-------------------|---------------------|
| 001 Gear unit housing | 145 Locking ring | 225 Seal |
| 101 Output shaft | 160 Shaft seal | 301 Plug-in pinion |
| 103 Spacer/bush | 201 Adapter plate | 305 Gear wheel |
| 105 Parallel key | 205 Bolt | 335 Parallel key |
| 130 Bearings | 210 Bolt | 401 Screw plug |
| 135 Locking ring | 211 Screw lock | 420 Breather filter |
| 136 Locking ring | 220 Seal | 430 Eye bolt |
| 140 Bearings | | |

12.2.2 Two and three-stage helical gear units

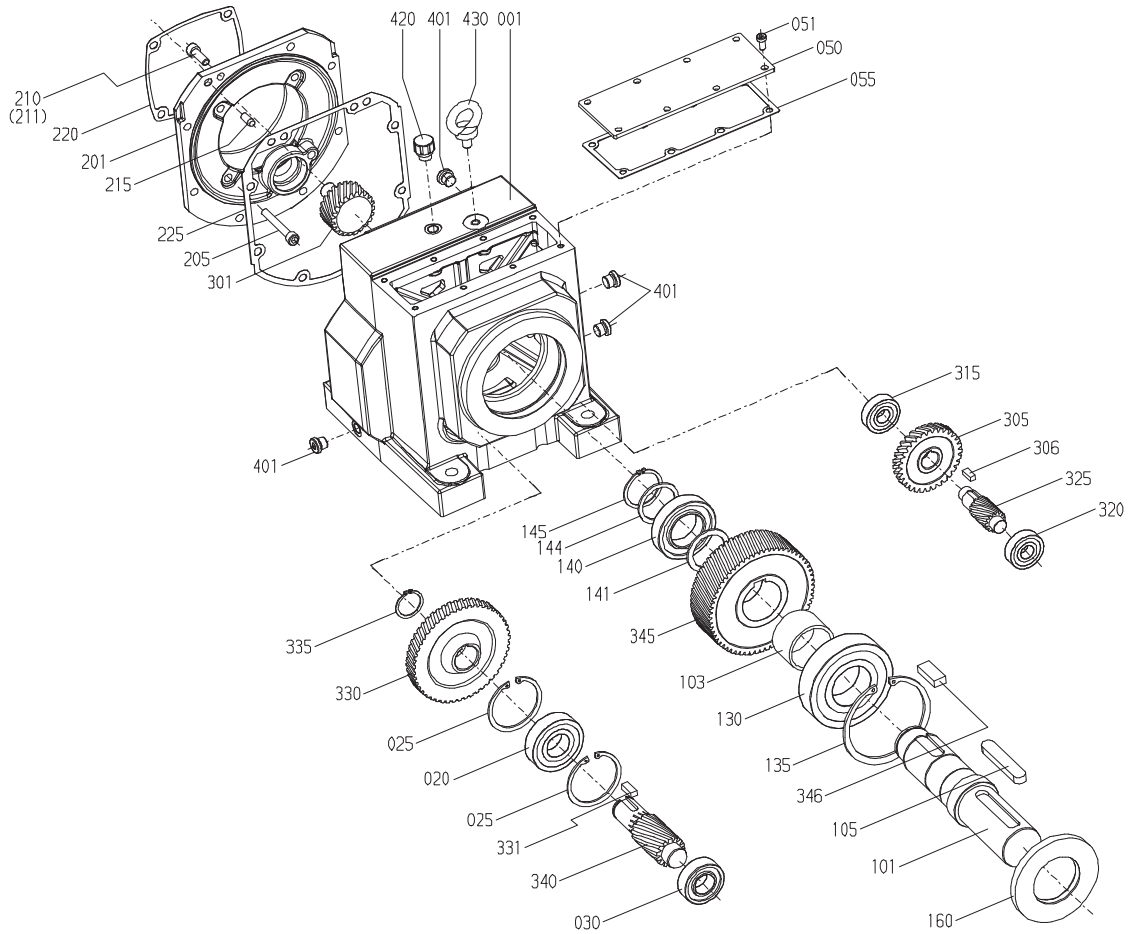

- 001 Gear unit housing
- 020 Bearings
- 025 Locking ring
- 030 Bearings
- 050 Housing cover
- 051 Bolt
- 055 Seal
- 101 Output shaft
- 103 Spacer/bush
- 105 Parallel key
- 130 Bearings
- 135 Locking ring
- 140 Bearings

- 141 Supporting disk/shim
- 144 Supporting disk/shim
- 145 Locking ring
- 160 Shaft seal
- 201 Adapter plate
- 205 Bolt
- 210 Bolt
- 211 Screw lock
- 215 Parallel pin
- 220 Seal
- 225 Seal
- 301 Plug-in pinion
- 305 Gear wheel

- 306 Parallel key
- 315 Bearings
- 320 Bearings
- 325 Pinion shaft
- 330 Gear wheel
- 331 Parallel key
- 340 Pinion shaft
- 345 Gear wheel
- 346 Parallel key
- 401 Screw plug
- 420 Breather filter
- 430 Eye bolt

12.2.3 Bevel-helical gear units

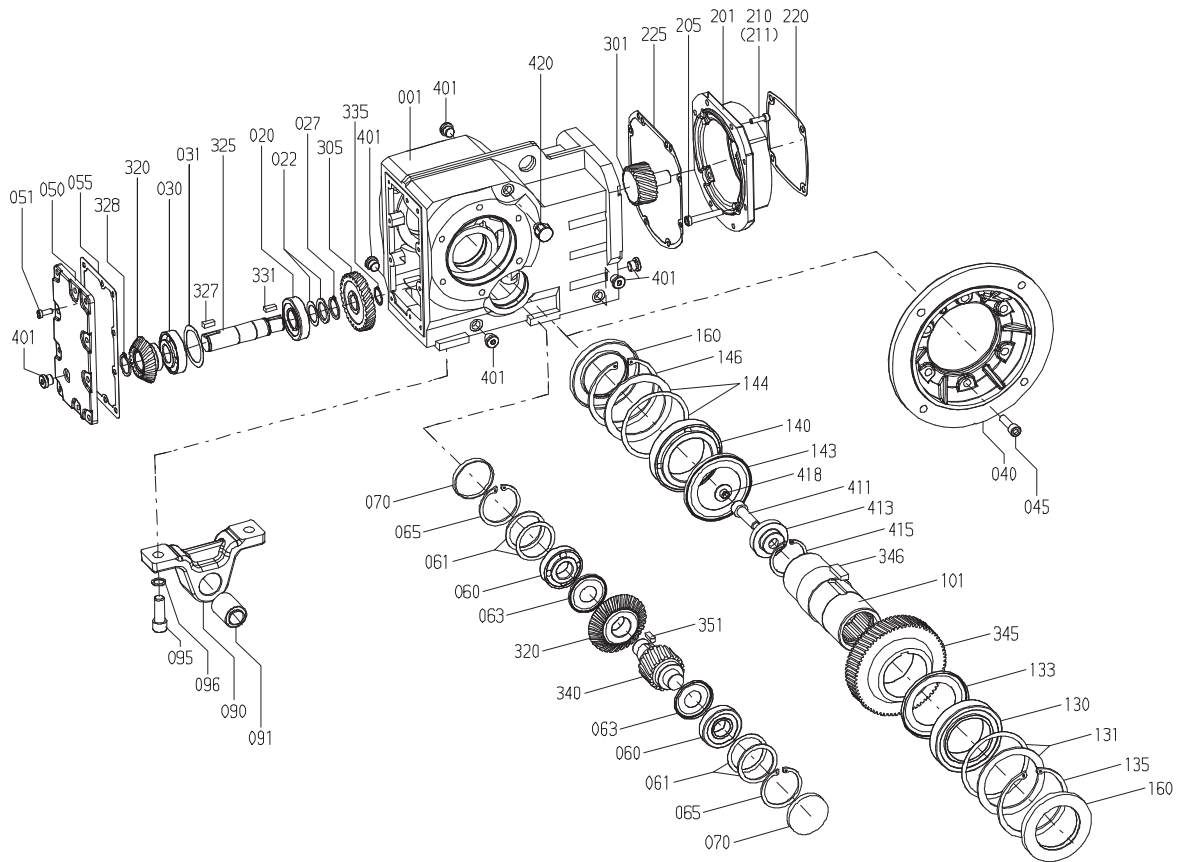

- | | | |
|--------------------------|--------------------------|------------------------|
| 001 Gear unit housing | 095 Bolt | 301 Plug-in pinion |
| 020 Bearings | 096 Screw lock | 305 Gear wheel |
| 022 Supporting disk/shim | 101 Output shaft | 320 Bevel-gear pair |
| 027 Locking ring | 130 Bearings | 325 Bevel pinion shaft |
| 030 Bearings | 131 Supporting disk/shim | 327 Parallel key |
| 031 Supporting disk/shim | 133 Nilos ring | 328 Locking ring |
| 040 Output flange | 135 Locking ring | 331 Parallel key |
| 045 Bolt | 140 Bearings | 335 Locking ring |
| 050 Housing cover | 143 Nilos ring | 340 Pinion shaft |
| 051 Bolt | 144 Supporting disk/shim | 345 Gear wheel |
| 055 Seal | 146 Locking ring | 346 Parallel key |
| 060 Bearings | 160 Shaft seal | 351 Parallel key |
| 061 Supporting disk/shim | 201 Adapter plate | 401 Screw plug |
| 063 Nilos ring | 205 Bolt | 411 Bolt |
| 065 Locking ring | 210 Bolt | 413 Washer |
| 070 Sealing cap | 211 Screw lock | 415 Locking ring |
| 090 Torque arm | 220 Seal | 418 Plug/sealing cap |
| 091 Rubber bush | 225 Seal | 420 Breather filter |

12.2.4 Parallel shaft helical gear units

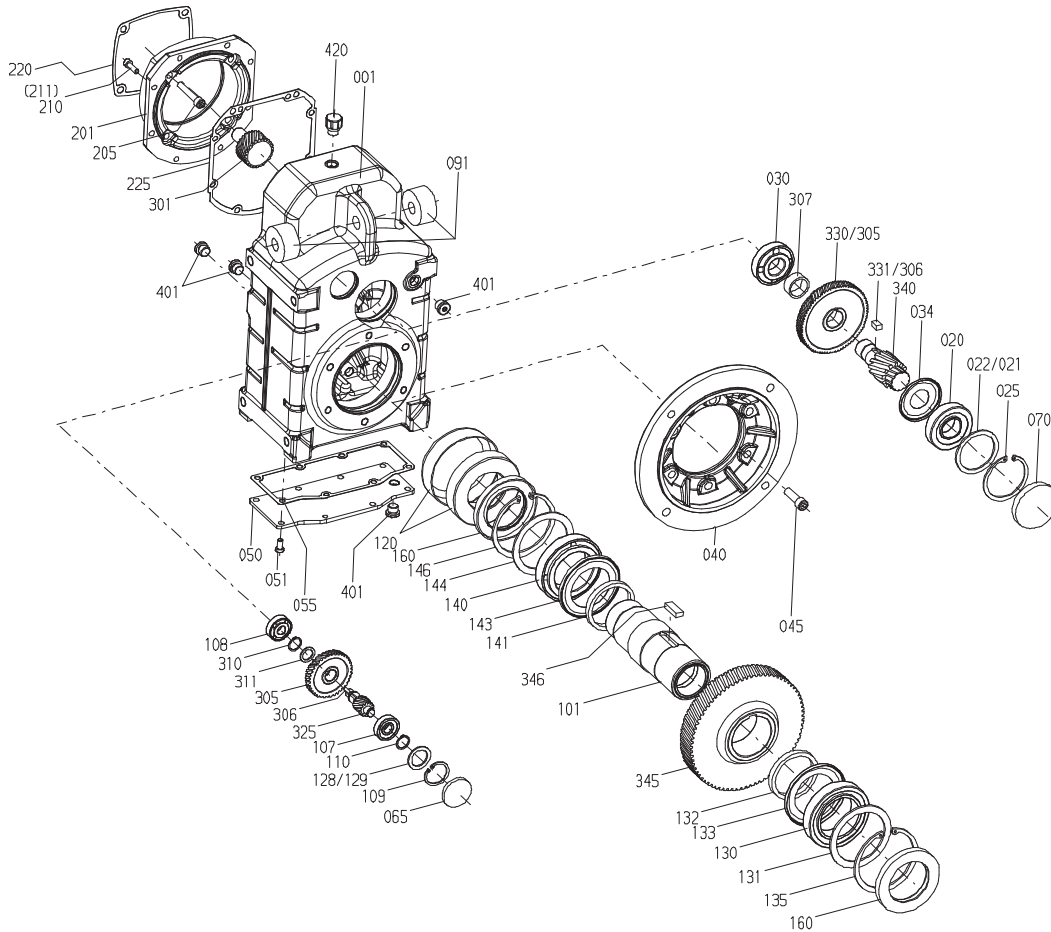

- | | | |
|--------------------------|--------------------------|--------------------------|
| 001 Gear unit housing | 109 Locking ring | 210 Bolt |
| 020 Bearings | 110 Locking ring | 211 Screw lock |
| 021 Supporting disk/shim | 120 Shrink disc | 220 Seal |
| 022 Supporting disk/shim | 128 Supporting disk/shim | 225 Seal |
| 025 Locking ring | 129 Supporting disk/shim | 301 Pinion |
| 030 Bearings | 130 Bearings | 305 Gear wheel |
| 034 Nilos ring | 131 Supporting disk/shim | 306 Parallel key |
| 040 Output flange | 132 Spacer/bush | 307 Spacer/bush |
| 045 Bolt | 133 Nilos ring | 310 Locking ring |
| 050 Housing cover | 135 Locking ring | 311 Supporting disk/shim |
| 051 Bolt | 140 Bearings | 325 Pinion shaft |
| 055 Seal | 141 Spacer/bush | 330 Gear wheel |
| 065 Sealing cap | 143 Nilos ring | 331 Parallel key |
| 070 Sealing cap | 144 Supporting disk/shim | 340 Pinion shaft |
| 091 Rubber bush | 146 Locking ring | 345 Gear wheel |
| 101 Drive shaft | 160 Shaft seal | 346 Parallel key |
| 107 Bearings | 201 Adapter plate | 401 Screw plug |
| 108 Bearings | 205 Bolt | 420 Breather filter |

12.2.5 Helical worm gear units

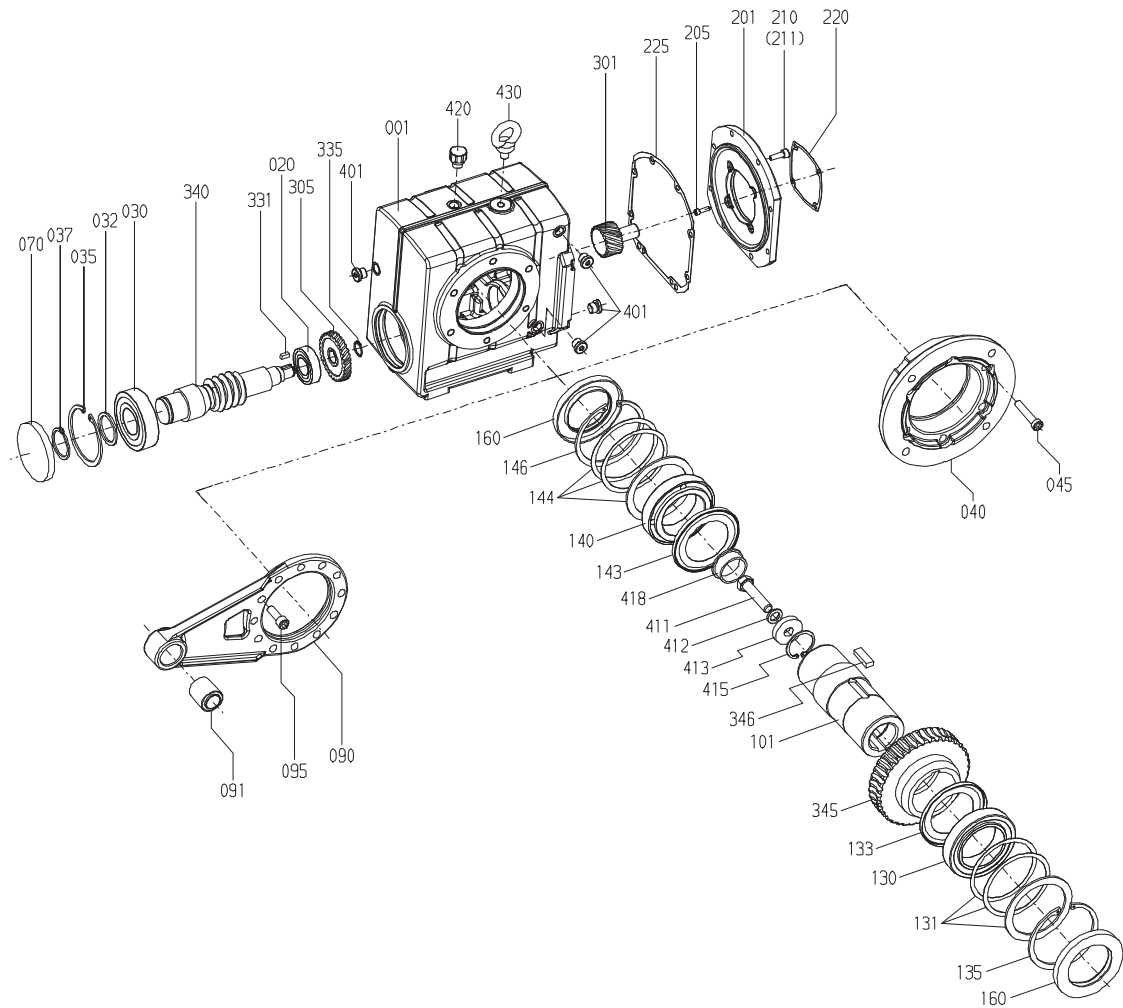

- | | | |
|--------------------------|--------------------------|----------------------|
| 001 Gear unit housing | 133 Nilos ring | 305 Gear wheel |
| 020 Bearings | 135 Locking ring | 331 Parallel key |
| 030 Bearings | 140 Bearings | 335 Locking ring |
| 032 Supporting disk/shim | 143 Nilos ring | 340 Worm shaft |
| 035 Locking ring | 144 Supporting disk/shim | 345 Worm wheel |
| 037 Locking ring | 146 Locking ring | 346 Parallel key |
| 040 Output flange | 160 Shaft seal | 401 Screw plug |
| 045 Bolt | 201 Adapter plate | 411 Bolt |
| 070 Sealing cap | 205 Bolt | 412 Screw lock |
| 090 Torque arm | 210 Bolt | 413 Washer |
| 091 Rubber bush | 211 Screw lock | 415 Locking ring |
| 095 Bolt | 220 Seal | 418 Plug/sealing cap |
| 101 Output shaft | 225 Seal | 420 Breather filter |
| 130 Bearings | 301 Plug-in pinion | 430 Eye bolt |
| 131 Supporting disk/shim | | |

13. Declaration by the manufacturer, Declaration of Conformity

13.1 Declaration by the manufacturer

in accordance with EC Engineering Guideline 98/37/EC, Appendix II B

We hereby declare that the

Single-stage helical gear units and gear motors of the types

| | | |
|-------------|--------------|--------------|
| E.38 | E.88 | E.148 |
| E.48 | E.108 | |
| E.68 | E.128 | |

Two- and three-stage helical gear units and gear motor of the types

| | | |
|----------------|-----------------|-----------------|
| D./Z.38 | D./Z.88 | D./Z.148 |
| D./Z.48 | D./Z.108 | D./Z.168 |
| D./Z.68 | D./Z.128 | D./Z.188 |

Bevel-helical gear units and gear motors of the types

| | | |
|-------------|--------------|--------------|
| K.38 | K.88 | K.148 |
| K.48 | K.108 | K.168 |
| K.68 | K.128 | K.188 |

Parallel-shaft helical gear units and gear motors of the types

| | | |
|--------------|---------------|---------------|
| F.38B | F.88B | F.148B |
| F.48B | F.108B | F.168B |
| F.68B | F.128B | F.188B |

Helical worm gear units and gear motors of the types

| | |
|-------------|-------------|
| C.38 | C.68 |
| C.48 | C.88 |

described in these operating instructions are intended for incorporation in a machine, and that it is prohibited to put them into service before verifying that the machine into which they are incorporated complies with the EC Guidelines 98/37/EC.

This Manufacturer's Declaration takes into account all the unified standards applying to our products in part or in whole published by the European Commission in the Official Journal of the European Community.

These include in particular:

- EN 292-1
- EN 292-2
- EEN 294
- EEN 349
- EN 60204-1

Tübingen, 03.05.2004

(p.p. Head of Gear Unit Development)

13.2 EC Declaration of Conformity



Document No. KE GKFSN298 DE / 07.03

Equipment designation: MOTOX[®]-N Gear-unit series
Type: E, Z, D, K, F, C
Sizes: 38 - 188
Add-on subassemblies: A, P, K

The designated equipment conforms to the requirements of the explosion protection guideline 94/9/EC. It has been developed and manufactured in conformity to the following European standards:

- EN 1050/1996
- pr EN 13463-5/2002
- pr EN 13463-6/2002
- EN 1127-1/1997
- pr EN 13463-8/2001
- EN 13463-1/2001
- EN 50281-1/-2/1999

Kind of explosion protection for equipment group II of category 2 and 3:

-  II2 G/D ck T4/120 °C
-  II2 G/D bck T4/120 °C
-  II3 G/D ck T4/120 °C

EC Declarations of Conformity and/or EC Type Test Certificates for further equipment added to the gear unit and/or for safety systems are enclosed.

These may be specifically:

- Rotating electrical machines
- Safety systems for oil level and/or temperature monitoring equipment.

The technical documentation for gear units of category 2 has been subjected to a voluntary inspection and filed with the specified office no. 0123 TÜV PRODUCT SERVICE GmbH, Ridlerstraße 31, D-80339 München.

Tübingen, 03.05.2004  (p.p. Head of Gear Unit Development)  (p. p. Head of Quality Management)